



Land of Cheese, Trees and Ocean Breeze

## Neskowin Coastal Hazard Area Permit #851-24-000313-PLNG: Ready2Market/Wells Fargo Bank

*NOTICE TO MORTGAGEE, LIENHOLDER, VENDOR OR SELLER:  
ORS 215 REQUIRES THAT IF YOU RECEIVE THIS NOTICE,  
IT MUST BE PROMPTLY FORWARDED TO THE PURCHASER*

### NOTICE OF ADMINISTRATIVE REVIEW Date of Notice: October 3, 2024

Notice is hereby given that the Tillamook County Department of Community Development is considering the following:

**#851-24-000313-PLNG:** A request for approval of a Neskowin Coastal Hazard Area Permit for the construction of a single-family dwelling, to rebuild after a fire, on a property located within the Unincorporated Community Boundary of Neskowin, zoned Neskowin Low Density Residential (NeskR-1) and within the Neskowin Coastal Hazards Overlay (Nesk-CH) Zone. The subject property is accessed via Breakers Blvd and designated as Tax Lot 92411 of Section 25CB in Township 5 South, Range 11 West of the Willamette Meridian, Tillamook County, Oregon. The applicant is Ready2Market and the property owner is Wells Fargo Bank.

Notice of the application, a map of the subject area, and the applicable criteria are being mailed to all property owners within 250 feet of the exterior boundaries of the subject parcel for which the application has been made and other appropriate agencies at least 14 days prior to this Department rendering a decision on the request.

Written comments received by the Department of Community Development prior to 4:00p.m. on October 17, 2024, will be considered in rendering a decision. Comments should address the criteria upon which the Department must base its decision. A decision will be rendered no sooner than October 18, 2024.

A copy of the application, along with a map of the request area and the applicable standards/criteria for review are available for inspection on the Tillamook County Department of Community Development website: <https://www.tillamookcounty.gov/commdev/landuseapps> and is also available for inspection at the Department of Community Development office located at 1510-B Third Street, Tillamook, Oregon, 97141.

If you have any questions about this application, please contact Melissa Jenck, CFM, Senior Planner at 503-842-3408 x 3301 or by email: [melissa.jenck@tillamookcounty.gov](mailto:melissa.jenck@tillamookcounty.gov).

Sincerely,

Melissa Jenck, CFM, Senior Planner

Sarah Absher, CFM, Director

Enc.     Applicable Ordinance Standards/Criteria  
             Maps

**TCLUO SECTION 3.570(4)(e): A decision to approve a Neskowin Coastal Hazard Area Permit shall be based upon findings of compliance with the following standards:**

- (A) The proposed development is not subject to the prohibition of development on beaches and certain dune forms as set forth in subsection (8) of this section;*
- (B) The proposed development complies with the applicable requirements and standards of subsections (6), (7), (8), and (10) of this section;*
- (C) The geologic report conforms to the standards for such reports set forth in subsection (5) of this section;*
- (D) The development plans for the application conform, or can be made to conform, with all recommendations and specifications contained in the geologic report; and*
- (E) The geologic report provides a statement that, in the professional opinion of the engineering geologist, the proposed development will be within the acceptable level of risk established by the community, as defined in subsection (5)(c) of this section, considering site conditions and the recommended mitigation.*

# EXHIBIT A

# Vicinity Map

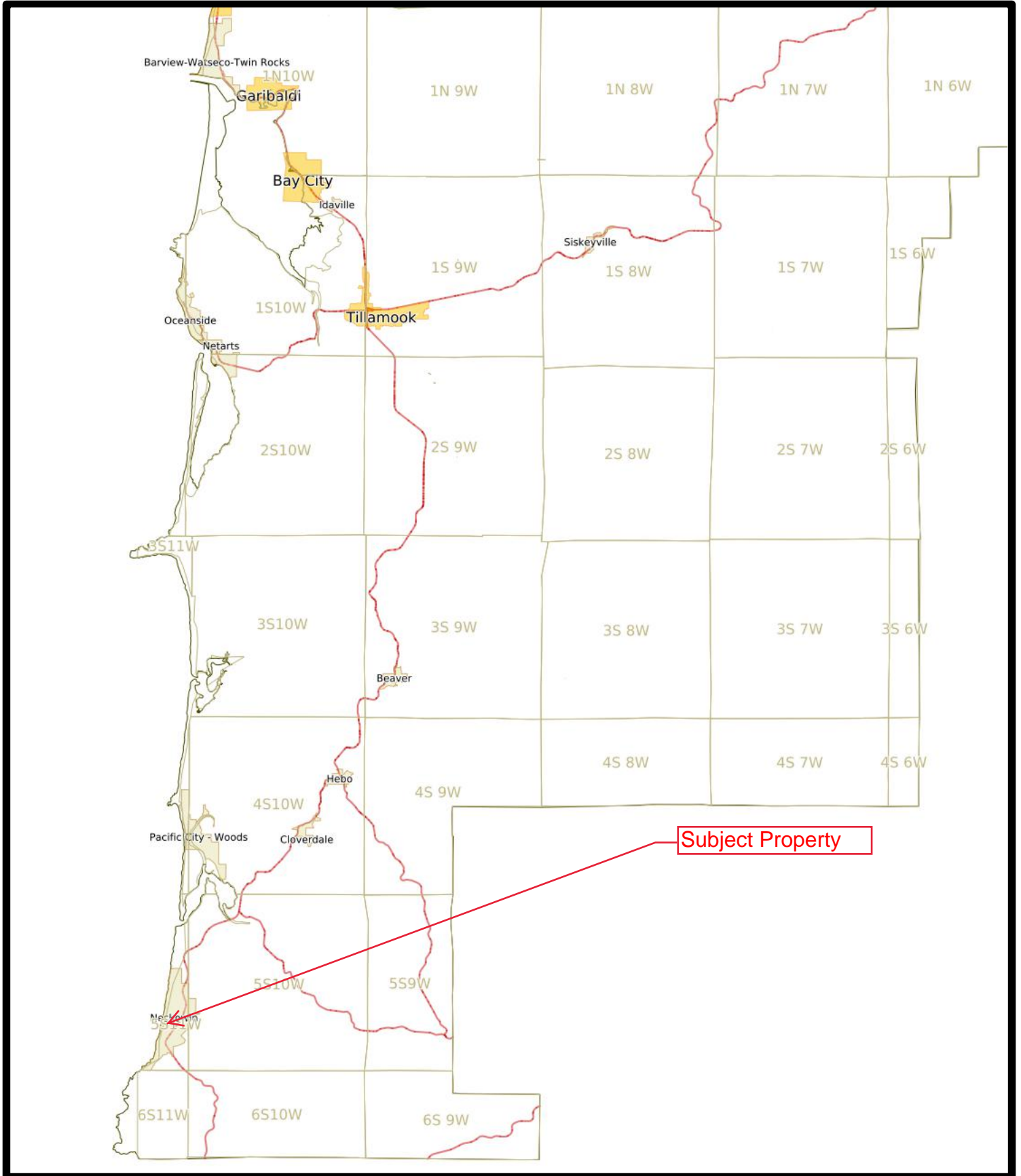

# Zoning Map

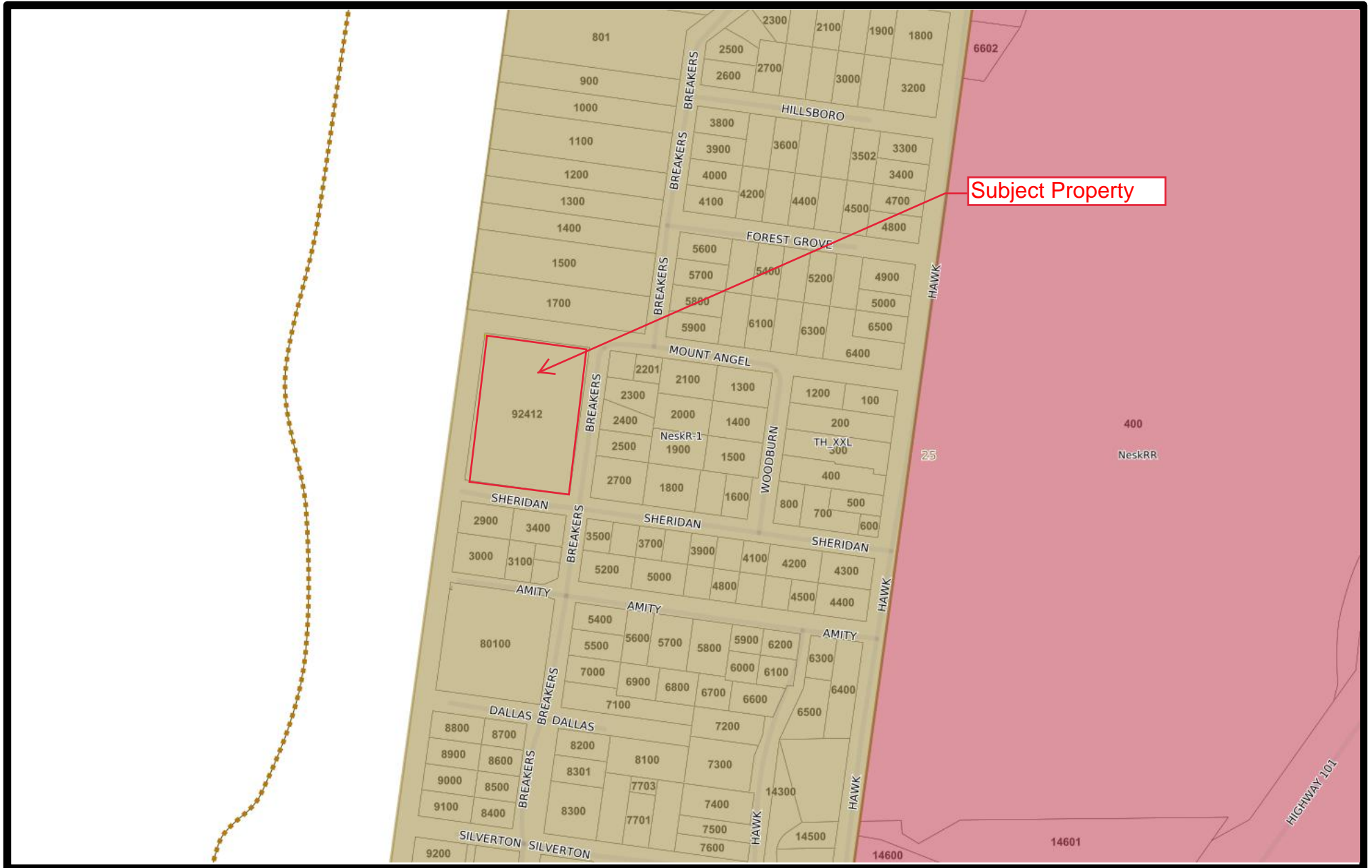

# NeskCH Overlay Map

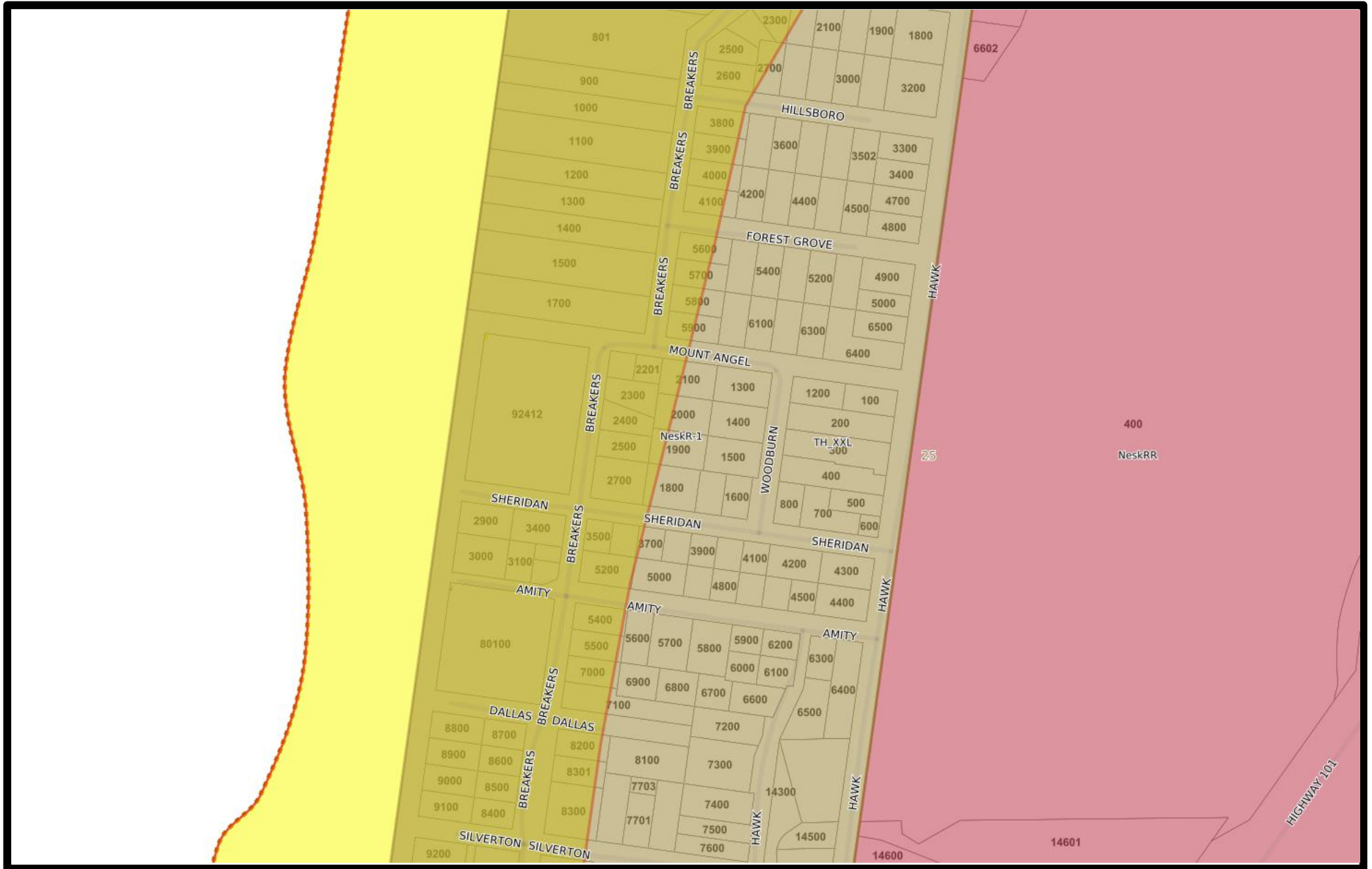

NW1/4 SW1/4 SEC. 25 T.5S R.11W. W.M.  
1" = 20'

THIS MAP WAS PREPARED FOR  
ASSESSMENT PURPOSE ONLY

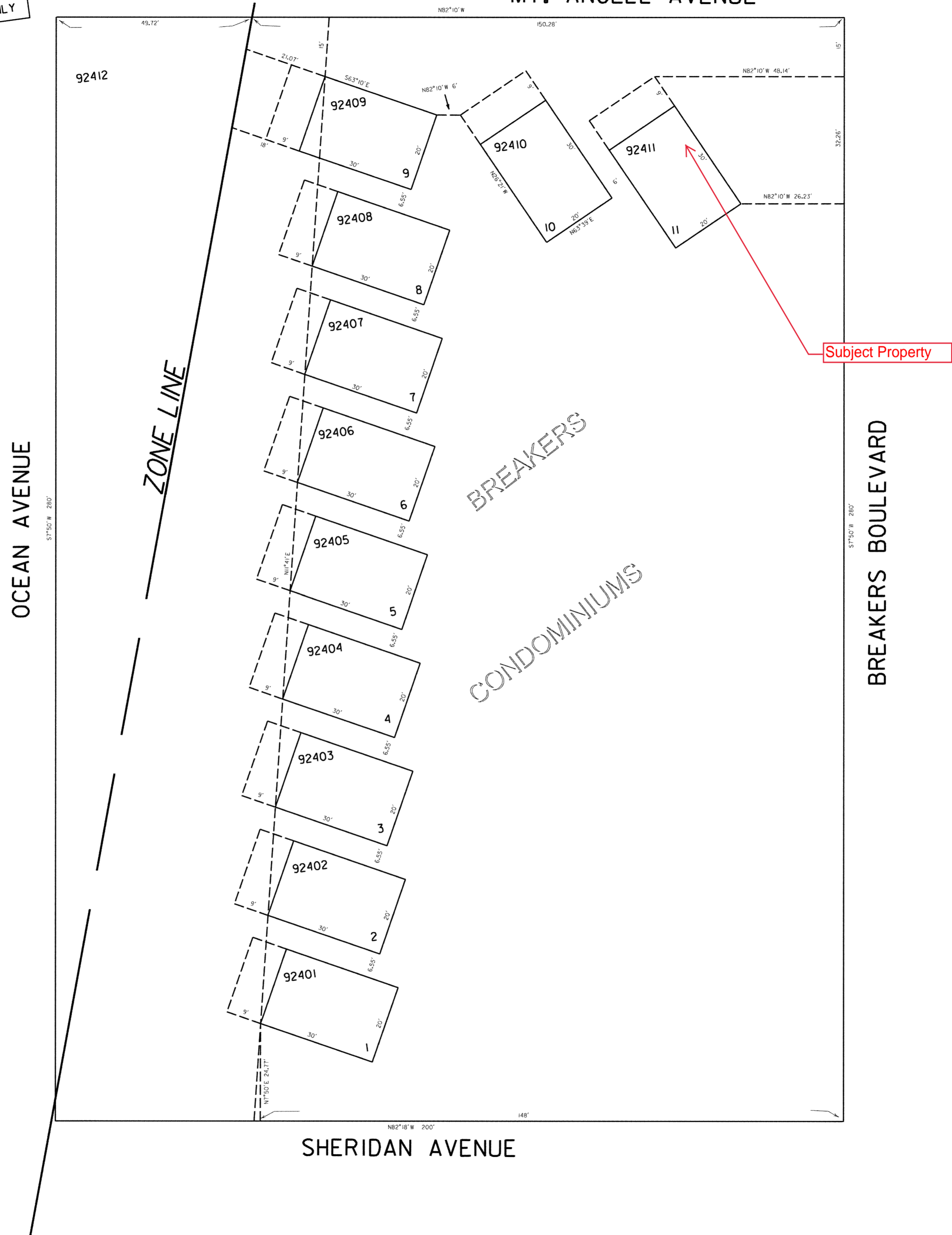

THIS MAP WAS PREPARED FOR ASSESSMENT PURPOSE ONLY

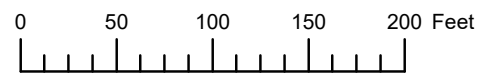

N.W.1/4 S.W.1/4 SEC.25 T.5S. R.11W. W.M.

TILLAMOOK COUNTY

05S11W25CB  
NESKOWIN

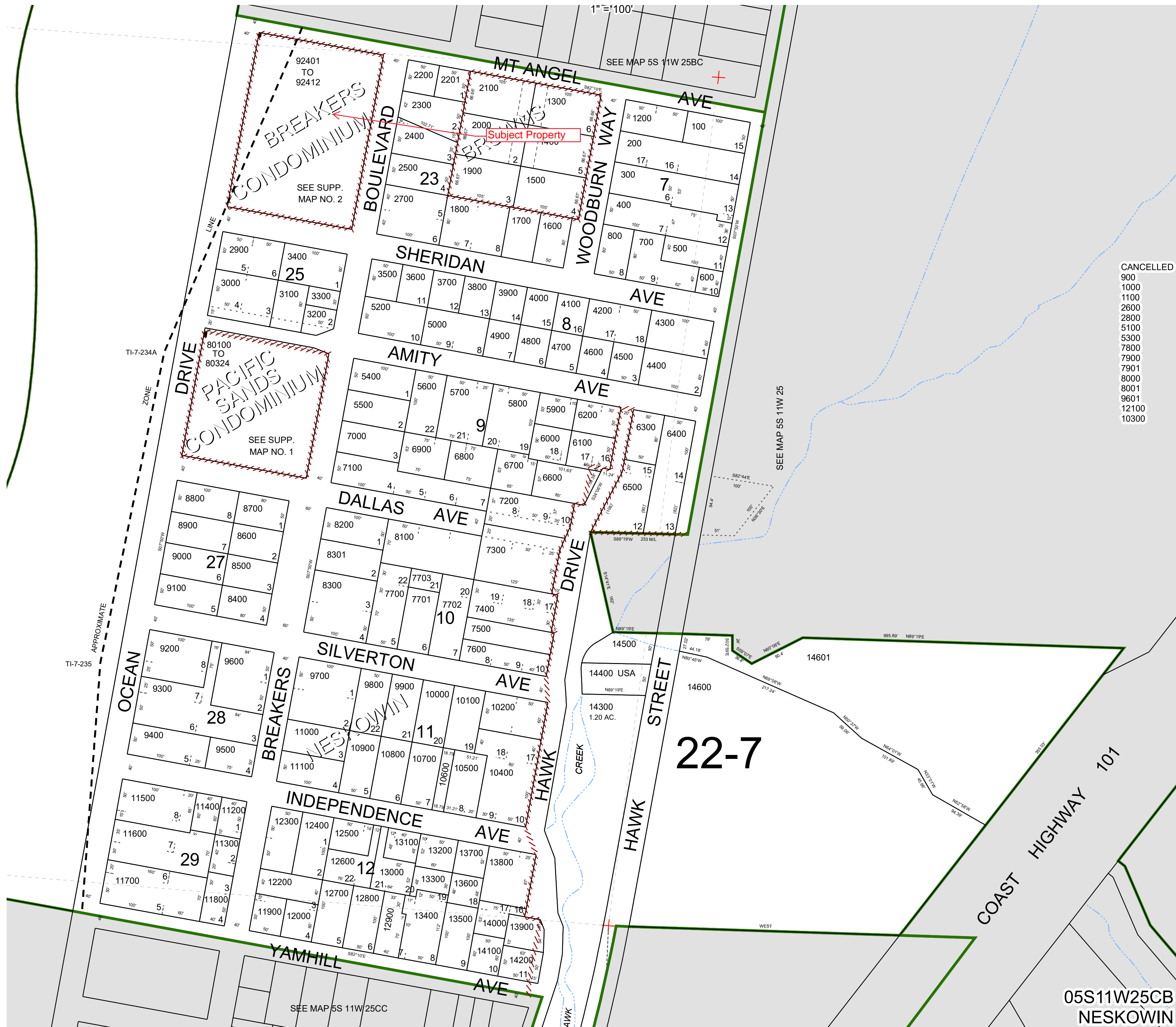

- CANCELLED
- 900
- 1000
- 1100
- 2600
- 2800
- 5100
- 5300
- 7800
- 7900
- 8000
- 8001
- 9601
- 12100
- 10300

22-7

05S11W25CB  
NESKOWIN

Revised 8/12/22, WS



**Tillamook County**  
**2023 Real Property Assessment Report**  
 Account 254673

<b>Map</b>	5S1125CB92411	<b>Tax Status</b>	Assessable
<b>Code - Tax ID</b>	2207 - 254673	<b>Account Status</b>	Active
		<b>Subtype</b>	NORMAL
<b>Legal Descr</b>	BREAKERS CONDO Lot - UNIT 11		
<b>Mailing</b>	WELLS FARGO BANK, N.A. TRUSTEE % RE0054610 PO BOX 35605 DALLAS TX 75235	<b>Deed Reference #</b>	2021-5546
		<b>Sales Date/Price</b>	06-24-2021 / \$0
		<b>Appraiser</b>	KARI FLEISHER
<b>Property Class</b>	112	<b>MA</b>	<b>SA</b>
		<b>NH</b>	
<b>RMV Class</b>	112	09	01 052

<b>Site</b>	<b>Situs Address</b>	<b>City</b>
-------------	----------------------	-------------

Value Summary					
Code Area	RMV	MAV	AV	RMV Exception	CPR %
<b>Grand Total</b>					

Land Breakdown									
Code Area	ID #	RFPD	Ex	Plan Zone	Value Source	Trend %	Size	Land Class	Trended RMV

Improvement Breakdown									
Code Area	ID #	Year Built	Stat Class	Description	Trend %	Total Sqft	Ex%	MS Acct	Trended RMV

Exemptions / Special Assessments / Notations
<b>Notations</b> <ul style="list-style-type: none"> <li>■ ACT OF GOD RMV &amp; MAV ADJUSTED 308.146 ADDED 2023</li> <li>■ ACT OF GOD PRORATED 308.425 ADDED 2022</li> <li>■ DESTROYED OR DAMAGED PROPERTY, JULY 1 ASMT DATE 308.146(6) ADDED 2023</li> </ul>

**Comments**      5/25/04 Added year built and changed stat class. dv.    8/11/09 Changed stat to 143.LM  
 2/27/15 Added sq ft to condo. SLK  
 6/16/23 Owner applied for July 1 re-assessment. Condo unit was damaged during a fire that occurred on Sept 2022. Condo was fully demolished prior to July 1. Adjusted RMV/MAV. KF

# Hazard Map - B&D

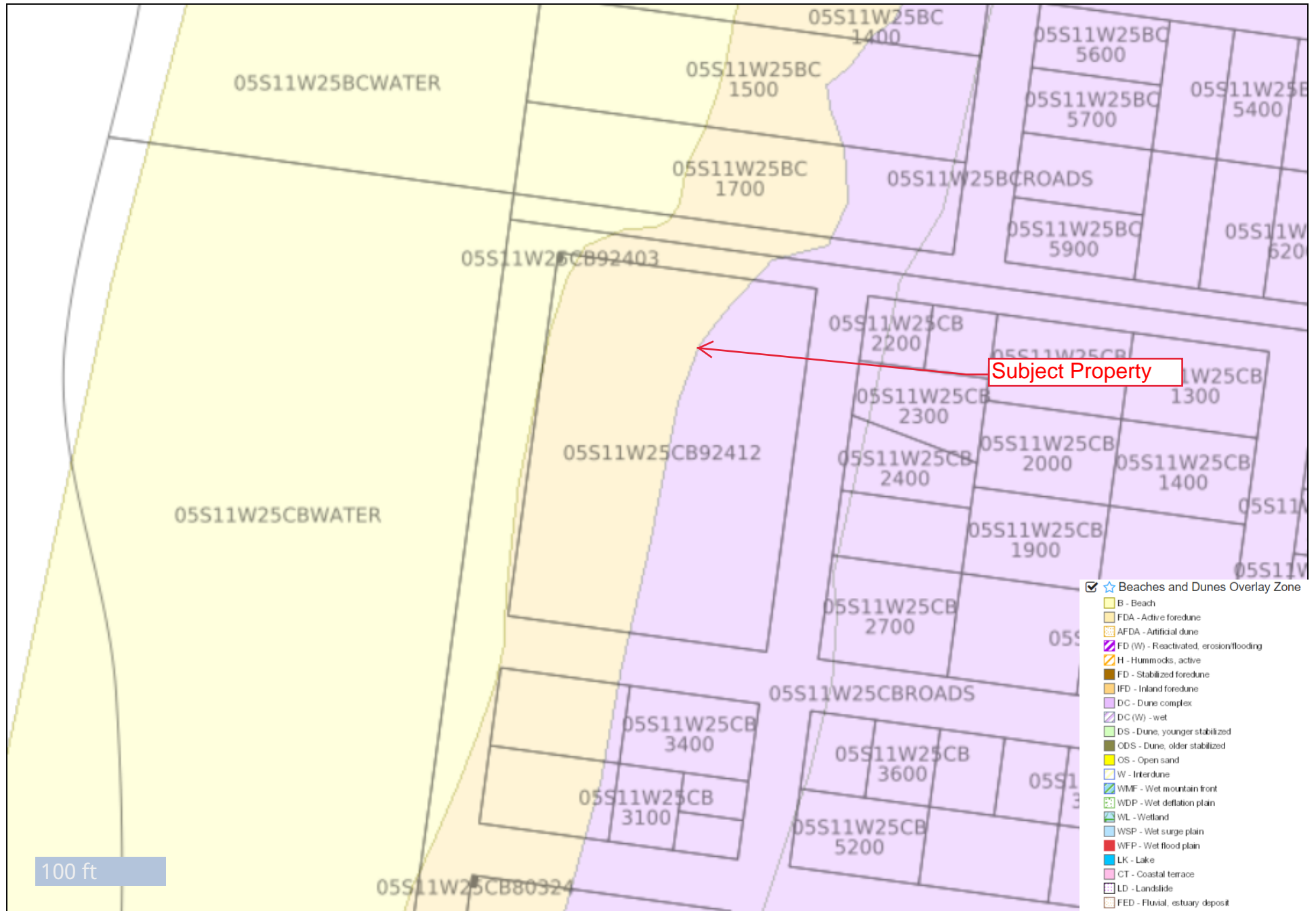

**Disclaimer:** The spatial information hosted at this website was derived from a variety of sources. Care was taken in the creation of these themes, but they are provided "as is". The state of Oregon, or any of the data providers cannot accept any responsibility for errors, omissions, or positional accuracy in the digital data or underlying records. There are no warranties, expressed or implied, including the warranty of merchantability or fitness for a particular purpose, accompanying any of these products. However, notification of any errors would be appreciated. The data are clearly not intended to indicate the authoritative location of property boundaries, the precise shape or contour of the earth or the precise location of fixed works of humans.

# Hazard Map - Geologic

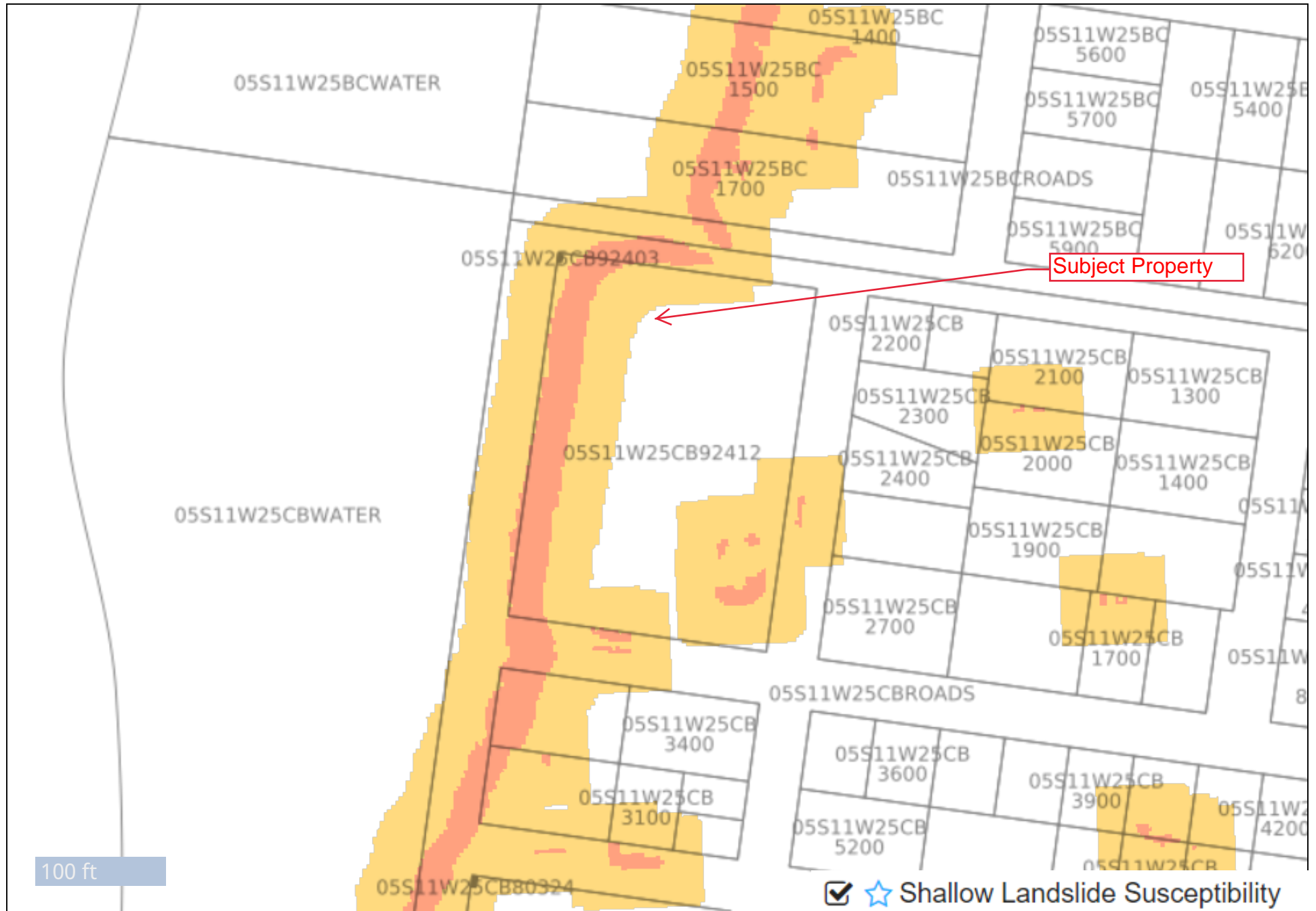

**Disclaimer:** The spatial information hosted at this website was derived from a variety of sources. Care was taken in the creation of these themes, but they are provided "as is". The state of Oregon, or any of the data providers cannot accept any responsibility for errors, omissions, or positional accuracy in the digital data or underlying records. There are no warranties, expressed or implied, including the warranty of merchantability or fitness for a particular purpose, accompanying any of these products. However, notification of any errors would be appreciated. The data are clearly not intended to indicate the authoritative location of property boundaries, the precise shape or contour of the earth or the precise location of fixed works of humans.

# Statewide Wetlands Inventory



- Townships
  - LWI Study Area
  - BASEDAT.DBO.NHDWaterbody
  - BASEDAT.DBO.NHDArea
- BASEDAT.DBO.NHDFlowline**
- Perennial
  - Intermittent
  - Ephemeral
  - Unknown
  - Canal/Ditch
  - Canal/Ditch
  - Canal/Ditch
  - BASEDAT.DBO.NHDPPoint
- Wetlands**
- Estuarine and Marine Deepwater
  - Estuarine and Marine Wetland
  - Freshwater Emergent Wetland
  - Freshwater Forested/Shrub Wetland
  - Freshwater Pond
  - Lake
  - Riverine
  - SWI Agate-Winlo Soils
  - SWI Predominantly Hydric Soil Map Units

R. Sounhen, Maxar, Microsoft, State of Oregon, State of Oregon GEO, Esri, HERE, Garmin, iPC, Department of State Lands, R. Sounhein 2018

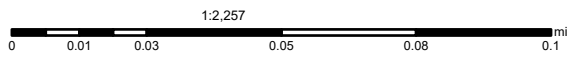

The Statewide Wetlands Inventory (SWI) represents the best data available at the time this map was published and is updated as new data becomes available. In all cases, actual field conditions determine the presence, absence and boundaries of wetlands and waters (such as creeks and ponds). An onsite investigation by a wetland professional can verify actual field conditions.



# EXHIBIT B



**Geotechnical Investigation (Phase 2)  
Tax Lot 92411, Map 5S-11W-25CB Supp. Map No. 2  
Lot-Unit 11, 48060 Breakers Boulevard  
Neskowin, Tillamook County, Oregon**

**Prepared for:  
Breakers Condominium  
Attn: Glenn Garrett, HOA President  
16476 NW Racely Court  
Portland, Oregon 97229**

Project #Y234676B

April 23, 2024



# H.G. Schlicker & Associates, Inc.

607 Main Street, Suite 200 · Oregon City, Oregon 97045  
(503) 655-8113 · FAX (503) 655-8173

Project #Y234676B

April 23, 2024

**To: Breakers Condominium  
Attn: Glenn Garrett, HOA President  
16476 NW Racely Court  
Portland, Oregon 97229**

**Subject: Geotechnical Investigation (Phase 2)  
Tax Lot 92411, Map 5S-11W-25CB Supp. Map No. 2  
Lot-Unit 11, 48060 Breakers Boulevard  
Neskowin, Tillamook County, Oregon**

**Dear Mr. Garrett:**

The accompanying report presents the results of our geotechnical investigation (phase 2) for the above subject site.

After you have reviewed our report, we would be pleased to discuss it and to answer any questions you might have.

This opportunity to be of service is sincerely appreciated. If we can be of any further assistance, please contact us.

**H.G. SCHLICKER & ASSOCIATES, INC.**

Adam M. Large, MSc, RG, CEG  
President/Principal Engineering Geologist

AML:mgb



**TABLE OF CONTENTS**

	<u>Page</u>
<b>1.0 Introduction and Project Description .....</b>	<b>1</b>
<b>2.0 Site Description .....</b>	<b>2</b>
<b>3.0 Geologic Mapping, Investigation and Descriptions .....</b>	<b>2</b>
<b>3.1 Subsurface Exploration and Observations.....</b>	<b>2</b>
<b>3.2 Liquefaction Hazards .....</b>	<b>3</b>
<b>4.0 Flooding Hazards.....</b>	<b>4</b>
<b>5.0 Conclusions and Recommendations.....</b>	<b>5</b>
<b>5.1 Development Density .....</b>	<b>6</b>
<b>5.2 Locations for Structures and Roads – Safest Site.....</b>	<b>6</b>
<b>5.3 Grading Practices .....</b>	<b>6</b>
<b>5.4 Vegetation Removal and Re-Vegetation Practices .....</b>	<b>6</b>
<b>5.5 Deep Foundations .....</b>	<b>7</b>
<b>5.6 Drainage and Stormwater Management .....</b>	<b>8</b>
<b>5.7 Erosion Control.....</b>	<b>8</b>
<b>5.8 Flooding Considerations.....</b>	<b>9</b>
<b>5.9 Seismic Considerations.....</b>	<b>9</b>
<b>5.10 Plan Review and Site Observations.....</b>	<b>9</b>
<b>5.11 Worker Safety .....</b>	<b>10</b>

**TABLE OF CONTENTS (continued)**

	<u>Page</u>
<b>6.0 Summary Findings and Conclusions.....</b>	<b>10</b>
<b>6.1 Proposed Use .....</b>	<b>10</b>
<b>6.2 Hazards to Life, Property, and the Environment .....</b>	<b>10</b>
<b>6.3 Off-Site Protection .....</b>	<b>11</b>
<b>6.4 Stabilization Programs .....</b>	<b>11</b>
<b>6.5 Conclusions Regarding Hazards and Adverse Environmental Effects .....</b>	<b>11</b>
<b>6.6 Recommendations for Further Work .....</b>	<b>11</b>
<b>7.0 Limitations.....</b>	<b>11</b>
<b>8.0 Disclosure.....</b>	<b>12</b>
<b>9.0 References.....</b>	<b>12</b>

**FIGURES**

- Figure 1 – Site Topographic Map**
- Figure 2 – Slope Profile A-A'**

**APPENDICES**

- Appendix A – Site Photographs**
- Appendix B – Boring Logs**
- Appendix C – Liquefaction Analysis**
- Appendix D – Pile Analysis**
- Appendix E – Checklist of Recommended Plan Reviews and Site Observations**



# H.G. Schlicker & Associates, Inc.

607 Main Street, Suite 200 · Oregon City, Oregon 97045  
(503) 655-8113 · FAX (503) 655-8173

Project #Y234676B

April 23, 2024

**To: Breakers Condominium  
Attn: Glenn Garrett, HOA President  
16476 NW Racely Court  
Portland, Oregon 97229**

**Subject: Geotechnical Investigation (Phase 2)  
Tax Lot 92411, Map 5S-11W-25CB Supp. Map No. 2  
Lot-Unit 11, 48060 Breakers Boulevard  
Neskowin, Tillamook County, Oregon**

**Dear Mr. Garrett:**

## **1.0 Introduction and Project Description**

At your request and authorization, we visited the subject site on November 2, December 13, 2023, and February 15, 2024, to complete a geotechnical investigation. Previously, we completed a Geologic Hazards Investigation (Phase 1) (dated May 23, 2023) at Tax Lot 92411, Map 5S-11W-25CB Supp. Map No. 2, Lot-Unit 11, 48060 Breakers Boulevard, Neskowin, Tillamook County, Oregon. In our earlier report, we recommended that a second-phase investigation be completed to explore and characterize subsurface materials at the site and provide geotechnical recommendations for deep foundations. It is our understanding that you are planning to construct a new house at the site.

This report addresses the subsurface conditions at the site and provides geotechnical recommendations for construction. The scope of our work consisted of a review of our previous geologic hazards report, site observations and measurements, subsurface exploration using a mud rotary drill rig, in-situ soil testing, and soil sampling, geotechnical analysis, and a report of our findings, conclusions and geotechnical recommendations for design and construction. This report also includes some, but not all, of the information from our earlier report for ease of use by the reader. For permitting purposes, both our previous report (Phase 1) and this report (Phase 2) should be submitted to the county.

## **2.0 Site Description**

The subject site consists of Tax Lot 92411, Map 5S-11W-25CB Supp. Map No. 2, which is approximately 20 feet wide and 30 feet deep. The rectangular-shaped lot is located on a younger stabilized dune at the Breakers Condominiums in the community of Neskowin, Oregon (Figure 1). The site is one of eleven condominium tax lots located within Tax Lot 92412, Map 5S-11W-25CB, which encompasses the greater area of the Breakers Condominiums.

An oceanfront protective structure (riprap revetment) is located on the dune slope approximately 105 feet west of the site; this revetment is contiguous with other revetments to the north and south (Appendix A). However, a gap in the riprap is present at the nearby beach access northwest of the site. The condominium property surrounding the site is bounded to the west by the beach and the Pacific Ocean, to the north by Mt. Angel Avenue, to its east by Breakers Boulevard, and to its south by Sheridan Avenue.

During our previous Geologic Hazards Investigation the site was occupied by a fire-damaged residential structure and attached deck. Since the time of our previous work, the damaged house was demolished, the foundation was removed for equipment access, and a drilling pad was graded using sand (Appendix A). Based on our review of the document provided to us, a surveyor completed an elevation certificate before the demolition of the previous structure.

## **3.0 Geologic Mapping, Investigation and Descriptions**

The site lies in an area that has been mapped as Pleistocene beach sand (Schlicker et al., 1972). Neskowin lies on a large dune complex, which is approximately 4 miles long, north to south and extends from the coastline east to the base of the hills. This dune complex consists of numerous individual dunes which vary in age and stability. The area of the site has been mapped as a younger stabilized dune (open dune sand conditionally stable), which is a dune that has become conditionally stable regarding wind erosion (USDA et al., 1975). More recent mapping also identifies the area of the site as recently stabilized dunes (Allan, 2020). The dune consists of tan, loose, fine-grained sand with a thin, moderately developed topsoil. Under the Land Conservation and Development Commission (LCDC) classification system, the site is a Dune, Younger Stabilized.

### **3.1 Subsurface Exploration and Observations**

At the time of our February 15, 2024, site visit, we completed one mud rotary boring with a CME-75 drill rig operated by Western States Soil Conservation to a depth of approximately 60 feet below the ground surface (bgs). Sampling was completed by obtaining and observing select cuttings brought up by the auger, and observing materials

recovered in split spoon samples from Standard Penetration Tests (SPTs) conducted at selected depth intervals to obtain in situ soil strength data based on penetration resistance (blow counts or “N” values). A geologist from our office visually classified and logged the soils encountered in the borehole according to the Unified Soil Classification System (USCS). A detailed description of subsurface conditions encountered during boring is provided in Appendix B, and the approximate location of the borehole is shown on Figures 1 and 2.

The boring generally encountered approximately 15 feet of loose to medium dense sand overlying approximately 20 feet of wet to saturated, dense sand from approximately 15 to 35 feet, underlain by organic-rich soft silty sand and peat from approximately 35 to 45 feet. From approximately 45 to 60 feet, dense to very dense, wet to saturated sand was encountered. Groundwater was encountered at approximately 12.5 feet.

### **3.2 Liquefaction Hazards**

#### **Liquefaction**

Liquefaction occurs when saturated, cohesionless soils are subjected to ground vibrations, resulting in a decrease in volume of the soil. If drainage is unable to occur, the tendency to decrease in volume results in an increase in pore water pressure, and if the pore water pressure builds up to the point at which it is equal to the overburden pressure, the effective stress becomes zero, and the soil loses its strength and develops a liquefied state. Liquefaction is most common in saturated, loose, granular soils, sand or silty sand materials. Cohesive soils, such as clayey silt and clay, will generally not liquefy during earthquakes. Older sediments are also more resistant to liquefaction than recently deposited sediments (Idris and Boulanger, 2008).

To determine the liquefaction potential of the site, we used the computer program LiquefyPro by CivilTech Software, which utilizes methods recommended by the 1996 NCEER Workshop to calculate liquefaction and seismic-induced settlement potential (Martin et al., 1999) (Appendix C).

For our analysis, we used an 8.8 magnitude Cascadia Subduction Zone earthquake, site-modified peak ground acceleration for Site Class D (default soil) of 0.77g, and the depth to water was set at 12.5 feet below the ground surface.

Based on our analysis, two zones of the soil column at the site are prone to liquefaction during the design earthquake due to the low strength, non-cohesive nature of sands near the groundwater table and the soft, organic-rich silty sands and peat. The liquefiable zones are estimated between approximately 12.5 to 16 feet and 34 to 43 feet.

DOGAMI’s HazVu website (<https://gis.dogami.oregon.gov/maps/hazvu/>) has mapped the area of the site as having a high susceptibility to liquefaction. DOGAMI states:

“Buildings and infrastructure sitting on these soils are likely to be severely damaged in an earthquake.”

#### Settlement

Settlement can be the result of liquefaction of saturated soils or simply a result of dry soil densifying under vibration (volumetric compression). Volumetric compression during an earthquake is the result of vibrations of the soil, which causes soil particles to settle into a denser state, decreasing the volume of the soil. The degree of settlement is primarily dependent upon the initial density of the soil and the magnitude and duration of ground vibration (shaking). Settlement caused by liquefaction is commonly differential, and the magnitude of settlement typically varies throughout a site, whereas settlement caused by volumetric compression tends to be more uniform.

Based on our analysis, the total amount of earthquake-induced liquefaction and volumetric compression is estimated at approximately 6.99 inches, and differential settlements can be expected to be as much as  $\frac{1}{2}$  to  $\frac{2}{3}$  of the total or approximately 3.5 to 4.7 inches (Appendix C). Because this settlement occurs above the recommended pile tip embedment depth, we would expect little to no settlement of a house founded on the recommended pile below.

#### **4.0 Flooding Hazards**

Based on the 2018 Flood Insurance Rate Map (FIRM, Panel #41057C1005F), the area of the site lies in an area rated as Zone VE (EL 32), defined as a special flood hazard area with base flood elevations determined, and subject to inundation by the 1-percent-annual-chance flood event with additional hazards due to storm-induced velocity wave action.

The beach and revetment area west of the site lies in an area rated as Zone VE (EL 41.3 feet) (NAVD 88), which is defined as a special flood hazard area with base flood elevations determined, and subject to inundation by the 1-percent-annual-chance flood event with additional hazards due to storm-induced velocity wave action. The area east of the revetment and west of the site lies in an area rated as Zone VE (EL 33), defined as a special flood hazard area with base flood elevations determined and subject to inundation by the 1-percent-annual-chance flood event with additional hazards due to storm-induced velocity wave action; the area east of the site is mapped as an area rated as Zone AE (EL 25) which is defined as an area of 1-percent-annual-chance of being flooded and wave heights are less than 3 feet.

Based on the Oregon Department of Geology and Mineral Industries mapping (DOGAMI, 2012), the subject site lies within the tsunami inundation zone resulting from an approximately 8.7 and greater magnitude Cascadia Subduction Zone (CSZ) earthquake. The 2012 DOGAMI mapping is based upon 5 computer-modeled scenarios for shoreline tsunami

inundation caused by potential CSZ earthquake events ranging in magnitude from approximately 8.7 to 9.1. The January 1700 earthquake event (discussed in Section 4.7 above) has been rated as an approximate 8.9 magnitude in DOGAMI's methodology. More distant earthquake source zones can also generate tsunamis.

## **5.0 Conclusions and Recommendations**

The main engineering geologic concerns at the site are:

1. The site lies on dune sands, which are poorly consolidated and subject to accretion and erosion from wind and wave attack. Inherent risks of coastal erosion and future dune sand movement and accretion activity at this site must be accepted by the owner, future owners, developers, and residents.
2. The site has shallow groundwater depths that are sensitive to tidal influences. Seasonal variation of groundwater depth and tidal influences can contribute to flooding at the site, particularly during storm events.
3. The site is mapped in a FEMA VE (EL 32) and is subject to a one percent or greater chance of flooding in any given year. The site lies in a coastal high hazard area, defined as an area of special flood hazard subject to high-velocity wave action from storms and seismic sources. These risks must be accepted by the owner, future owners, developers and residents of the site.
4. There is an inherent regional risk of earthquakes along the Oregon Coast which could cause harm and damage structures. Ground shaking during an earthquake can cause soils to liquefy, resulting in loss of bearing capacity and structural damage. The site also lies in a mapped tsunami inundation hazard zone. A tsunami impacting the Neskowin area could cause harm, loss of life, and damage to structures. These risks must be accepted by the owner, future owners, developers and residents of the site.

### **Recommendations**

Based on FEMA FIRM mapping and liquefaction potential, we recommend that new or substantially improved buildings at the site be supported on a deep foundation system. Foundations in V Zones should be on piers or piling capable of resisting simultaneous wind and flood loads (with wave action). Foundations will need to support vertical loads and provide support in the event of coastal erosion encroaching in the new foundation area. Foundations will also need to resist uplift forces, particularly for any cantilever-type house design. An open foundation or breakaway wall design may be necessary for the area below the lowest floor. V Zone standards should apply to the site, and we recommend that you design to these standards.

Typically, the lowest horizontal structural members of the new building should be a minimum of 1 foot or more above base flood elevations. Additional freeboard may be necessary.

During construction, disturbed, dry sands may be blown by winds, which can result in transport and deposition of sands off-site. Therefore, periodic watering or covering of exposed areas may be required to control blowing sands during windy conditions.

The following recommendations should be adhered to.

### **5.1 Development Density**

It is our understanding that only one single-family residence will be located at the site.

### **5.2 Locations for Structures and Roads – Safest Site**

Due to the lot's small size, we anticipate that the new house will occupy the entire site. No new roads or driveways are anticipated; existing access to the site is provided by the common parking lot.

Please note, that the Oregon Coast is a dynamic and energetic environment. Most of the coastline along this stretch of beach is slowly receding and will continue to recede in the future. Geologic conditions and the rates of geologic processes can change in the future.

### **5.3 Grading Practices**

We recommend the following grading practices:

Any organic soils, disturbed soils, and any existing fills should be stripped from grade beams, driveway, and slab areas prior to construction.

Based on the existing topography and the lot size at the site we do not anticipate significant temporary or permanent cuts and fills or grading to occur during construction.

Based on the FEMA Flood mapping, the use of permanent fill for structural support is not recommended. Any temporary grading and fill work necessary for equipment and construction access should be limited and indicated on the plan set.

### **5.4 Vegetation Removal and Re-Vegetation Practices**

Vegetation should be removed only as necessary, and exposed areas should be replanted following construction. Disturbed ground surfaces exposed during the wet season (November 1 through April 30) should be temporarily planted with grasses or protected with erosion control blankets or hydromulch.



## **5.5 Deep Foundations**

We recommend that the new house be placed on elevated beams supported on pile or columns with the lowest horizontal structural member no lower than 1 foot above the base flood elevation. We recommend that the foundation system consist of drilled and gravity grouted micropile.

### **5.5.1 Gravity Grouted Micropile**

We provide the following allowable micropile loads for 8 and 10-inch (drilled hole) diameter, 48 feet embedment length, gravity grouted pile based on grout-to-ground bond strengths from Table 5-21 in the Federal Highway Administration National Highway Institutes Micropile Design and Construction Reference Manual. The allowable loads were calculated with conservative bond ultimate strength values of 11 psi (1,584 psf) for the loose to medium sands between 12.5 and 35 feet and 14 psi (2,016 psf) for the dense sand between 43 and 48 feet. Bond ultimate strength for the upper 12.5 feet of fill and loose sands and the organic-rich silty sand and peat between approximately 35 and 43 feet were assumed to be negligible.

The use of permanent steel casing in the upper 12.5 feet of each pile is acceptable. All other temporary casing used during pile construction should be removed to achieve the assumed grout-to-ground strength used in our analysis.

The micropile capacities were determined using Allpile, version 7.8c, by Civiltech Software. Allowable bearing capacities and pullout resistance are provided below, and additional results from our analyses are provided in Appendix D.

GRAVITY GROUTED PILE ALLOWABLE LOADS		
Pile (Drilled Hole) Diameter	8 inches	10 inches
Allowable Pile Loads (Compression) (FOS = 2.5) <sup>a</sup>	38 kips	47 kips
Allowable Pile Loads (Tension) (FOS = 2.5) <sup>a</sup>	39 kips	50 kips
<sup>a</sup> A representative of HGSA should observe pile installation operations and verify achieved embedment depths on-site. Please provide us with at least five (5) days' notice prior to any needed site observations.		

The house can be placed on individual piles that extend up to the lowest horizontal framing member. Pile spacing and design can vary with the size and type of pile utilized, and the project's structural engineer should determine the above-ground elements of the foundation system. HGSA should work with the structural engineer and architect during the foundation design process.

Grade beams at the existing ground level can be used for lateral bracing based on structural considerations. Any new slab or flatwork at existing grade under the new house should be structurally independent of and detached from the pile foundation system and/or any grade beams.

Guidance and standards for breakaway walls and alternatives for breakaway walls below the BFE are provided in TCLUO 3.510 (10) (e) and FEMA-NFIP Technical Bulletin 9/September 2021.

Prior to construction, the foundation contractor should provide a work plan for HGSA's review (also refer to Appendix E).

A representative of HGSA should observe all pile construction and installation operations to ensure that suitable materials have been encountered and address any issues that may arise during construction (Appendix E).

Any structures and all structural elements should be designed to meet the current Oregon Residential Specialty Code (ORSC) and Oregon Structural Specialty Code (OSSC) seismic requirements.

#### **5.6 Drainage and Stormwater Management**

Surface water shall be diverted from building foundations and walls to approved disposal points by grading the ground surface to slope away a minimum of 2 percent for 6 feet towards a suitable gravity outlet to prevent ponding near the structures.

All roof and footing drains shall be discharged to an approved disposal point. If water will be discharged to the ground surface, we recommend that energy dissipaters, such as splash blocks or a rock apron, be utilized at all pipe outfall locations. Water collected on the site shall not be concentrated and discharged to adjacent properties.

#### **5.7 Erosion Control**

As detailed above, vegetation should be removed only as necessary, and exposed areas should be replanted following construction. Disturbed ground surfaces exposed during the wet season (November 1 through April 30) should be temporarily planted with grasses or protected with erosion control blankets.

A temporary sediment fence should be installed around and downslope disturbed areas of the site until permanent vegetation cover can be established.

**5.8 Flooding Considerations**

The recommendations provided herein are based on guidelines by FEMA and Tillamook County for construction within a coastal special flood hazard area. Adverse effects of coastal flooding will be minimized when all recommendations detailed in this report are adhered to. However, the site lies in an area subject to potential ocean flooding and erosion. These risks must be accepted by the owner, future owners, developers and residents of the site.

**5.9 Seismic Considerations**

The structure and all structural elements should be designed to meet current Oregon Residential Specialty Code (ORSC) and Oregon Structural Specialty Code (OSSC) seismic requirements as applicable. Based on the guidelines recommended in the ORSC and OSSC, the structure should be designed to meet the following seismic parameters:

SEISMIC DESIGN PARAMETERS	
Site Class	D
Seismic Design Category	D <sub>2</sub>
Mapped Spectral Response Acceleration for Short Periods	S <sub>s</sub> = 1.295g
Site Coefficient	F <sub>a</sub> = 1.200
Design Spectral Response Acceleration at Short Periods	S <sub>DS</sub> = 1.036g
Site-modified peak ground acceleration	PGA <sub>m</sub> = 0.77

**5.10 Plan Review and Site Observations**

Design Review

This report pertains to a specific site and development. It is not applicable to adjacent sites, nor is it valid for types of development other than that to which it refers. Any variation from the site or development plans necessitates a geotechnical review in order to determine the validity of the design concepts evolved herein.

HGSA’s review of final plans and specifications is necessary to determine whether the recommendations detailed in this report have been properly interpreted and incorporated into the design and construction documents. At the completion of our review, we will issue a letter of conformance to the client for the plans and specifications.

### Construction Monitoring

Because of the judgmental character of geotechnics, as well as the potential for adverse circumstances arising from construction activity, observations during site preparation, excavation, and construction will need to be carried out by a representative of HGSA or our designate. These observations may then serve as a basis for confirmation and/or alteration of geotechnical recommendations or design guidelines presented herein to the benefit of the project.

Field observations become increasingly important should earthwork proceed during adverse weather conditions. Oregon Structural Specialty Code requires full-time inspection of deep foundation construction by a qualified professional.

Also, it is our understanding that Tillamook County now requires us to complete an additional site visit and summary letter at the end of construction to obtain an occupancy permit. Please provide us with 5 days' notice prior to the needed observations.

### **5.11 Worker Safety**

All construction activities should be completed in accordance with OSHA standards and all State and local laws, rules, regulations, and codes.

## **6.0 Summary Findings and Conclusions**

Our summary findings and conclusions are presented below:

### **6.1 Proposed Use**

The proposed project consists of constructing a residential structure on the site. No new roads are anticipated. No adverse impacts are anticipated to occur on adjacent lots as a result of the development of this site, provided that the recommendations detailed in this report are adhered to.

### **6.2 Hazards to Life, Property, and the Environment**

Hazards to life, property and the environment associated with this proposed use include flooding, ocean wave erosion, and seismic hazards. Recommendations for mitigation of liquefaction, settlement, and oceanfront flooding and erosion have been incorporated into this report. Please note that the risk of these hazards is inherent with development and construction in this part of Tillamook County and must be assumed by the owner, future owners, developers, and residents.

### **6.3 Off-Site Protection**

Protection of the surrounding areas from any adverse effects of this development will be minimized when all the stormwater, vegetation, and erosion control recommendations detailed in this report are adhered to.

### **6.4 Stabilization Programs**

Stabilization programs for this site include vegetation and erosion stabilization, as addressed in Sections 5.4 and 5.7 of this report, and surface water collection, as addressed in Section 5.6 of this report.

### **6.5 Conclusions Regarding Hazards and Adverse Environmental Effects**

Adverse environmental effects will be minimized by following the recommendations detailed in this report during the design and construction of the proposed project.

### **6.6 Recommendations for Further Work**

Assuming the recommendations provided herein are adhered to, no additional investigation or analysis is required by our firm other than review of site development plans and observation of pile installation as detailed in Section 5.10 and Appendix E of this report.

## **7.0 Limitations**

The Oregon Coast is a dynamic environment with inherent, unavoidable risks to development. Landsliding, erosion, tsunami, storms, earthquakes and other natural events can cause severe impacts to structures built within this environment and can be detrimental to the health and welfare of those who choose to place themselves within this environment. The client is warned that, although this report is intended to identify the geologic hazards causing these risks, the scientific and engineering communities' knowledge and understanding of geologic hazard processes is not complete. This report pertains to the subject site only and is not applicable to adjacent sites nor is it valid for types of development other than that to which it refers. Geologic conditions including materials, processes and rates can change with time and therefore a review of the site and/or this report may be necessary as time passes to assure its accuracy and adequacy.

The boring logs and related information depict generalized subsurface conditions only at these specific locations and at the particular time the subsurface exploration was completed. Soil and groundwater conditions at other locations may differ from the conditions at these boring locations. Also, the passage of time may result in a change in the soil and groundwater conditions at the site.

Our investigation was based on engineering geological reconnaissance and a limited review of published information. The data presented in this report are believed to be representative of the site. The conclusions herein are professional opinions derived in accordance with current standards of professional practice and no warranty is expressed or implied. The performance of this site during a seismic event has not been fully evaluated. If you would like us to do so, please contact us. This report may only be copied in its entirety.

## **8.0 Disclosure**

H.G. Schlicker & Associates, Inc. and the undersigned Certified Engineering Geologist have no financial interest in the subject site, the project or the Client's organization.

## **9.0 References**

- Allan, J. C., 2020, Temporal and Spatial Changes in Coastal Morphology, Tillamook County, Oregon: Oregon Department of Geology and Mineral Industries, Open-File Report O-20-04, 27 p. report, geodatabase, metadata.
- DOGAMI, 2012, Tsunami inundation maps for Neskowin, Tillamook County, Oregon: Oregon Department of Geology and Mineral Industries, TIM-Till-114 maps.
- Idris, I. M., and Boulanger, R. W., 2008, Soil Liquefaction During Earthquakes: Earthquake Engineering Research Institute, 243 p.
- Martin, G. R., Lew, M. K., Baez, A. J. L., Blake, T. F., Ghardi, E. F., Hsu, G. D., Kupferman, S., O'Tousa, J., Real, C. R., Reeder, W., Simantob, E., and Youd, T. L, 1999, Guidelines for analyzing and mitigating liquefaction in California: Southern California Earthquake Center, Recommended Procedures for Implementation of DMG Special Publication 117, 63 p.
- Schlicker, H. G., Deacon, R. J., Beaulieu, J. D., and Olcott, G. W., 1972, Environmental geology of the coastal region of Tillamook and Clatsop Counties, Oregon: Oregon Department of Geology and Mineral Industries, Bulletin 74, 164 p., maps.
- USDA Soil Conservation Service, and Oregon Coastal Conservation and Development Commission, 1975, Beaches and dunes of the Oregon Coast: 161 p.

It has been our pleasure to serve you. If you have any questions concerning this report, or the site, please contact us.

Respectfully submitted,

**H.G. SCHLICHER AND ASSOCIATES, INC.**

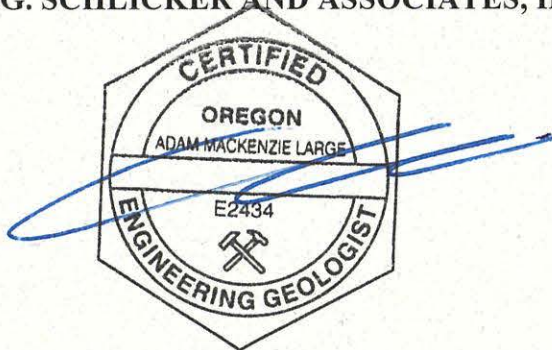

EXPIRES: 12/31/2024

Adam M. Large, MSc, RG, CEG  
President/Principal Engineering Geologist

AML:mgb

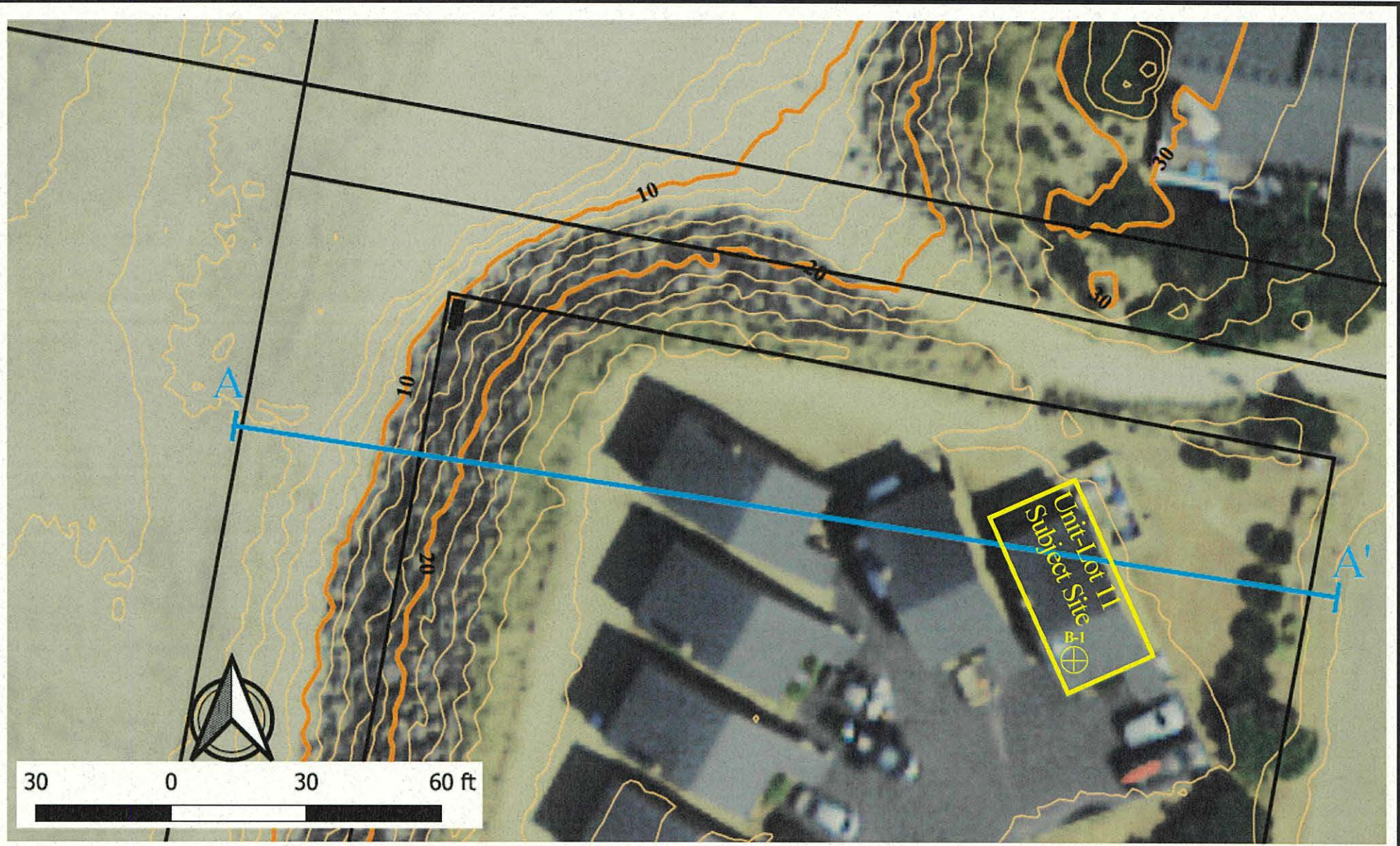

Imagery provided by 2018 Oregon Explorer  
 Topographic data derived from West\_Coast\_2016\_El\_Nino Lidar data from NOAA  
 All locations and dimensions are approximate.

**B-1**  
 = Approximate location of drilled boring

**A** **A'**  
 = Approximate trend of profile line

Date: 04/23/2024

Scale: 1" = 30'

**Project #Y234676B**

Prepared by: MGB

Approved by: AML

**Site Topographic Map**

Tax Lot 92411, Map 5S-11W-25CB Supp. No. 2; Lot-Unit 11  
 48060 Breakers Blvd, Neskowin, Tillamook County, Oregon



**H.G. Schlicker & Associates, Inc.**

**Figure 1**



A

North 83° West

A'

Approximate Location  
Of Western Boundary  
Condominium Property

Approximate Location  
Of Eastern Boundary  
Condominium Property

Approximate Location  
of Unit-Lot 11  
Subject  
Site

Breakers Condominium Property  
Other Individual Lots and Units Not Shown

Breakers Blvd

Beach



SPT	Depth	Description
N = 11	7.5'	Loose to Medium Dense Sands
N = 18	12.5'	Approximate Groundwater Level
N = 31	25'	Medium Dense to Dense Sands
N = 7	37.5'	Soft, Organic Rich, Silty Sands and Peat
N = 22	40'	
N = 39	45'	Very Dense Sands
N = 48	50'	
50 Blows for 6"	60'	

Elevation (ft.) (NAVD88)

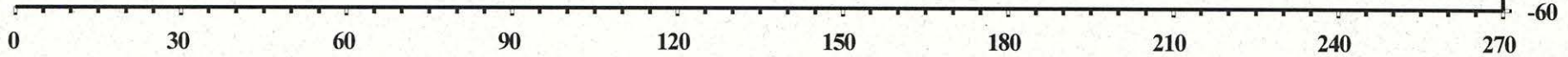

--- = Geologic contact, queried where inferred

All dimensions, elevations and locations are approximate.  
Slope profile derived from West\_Coast\_2016\_El\_Nino Lidar data from NOAA.

Date: 04/23/2024	<b>Project #Y234676B</b>	Prepared by: MGB
Scale: 1" = 30'		Approved by: AML
<b>Slope Profile, A-A'</b> Tax Lot 92411, Map 5S-11W-25CB Supp. No. 2 Lot-Unit 11, 48060 Breakers Blvd., Neskowin, Tillamook County, Oregon		
 <b>H.G. Schlicker &amp; Associates, Inc.</b>		<b>Figure 2</b>

Project #Y234676B

Appendix A  
- Site Photographs -



Photo 1 – View of the foundation of the previous house at the site after demolition.

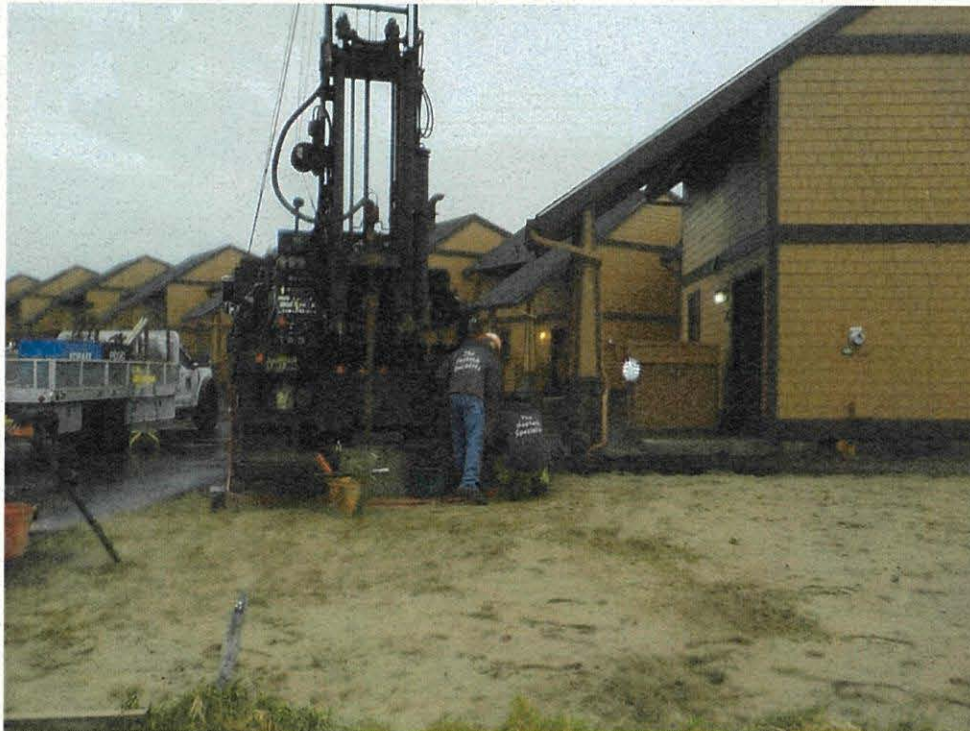

Photo 2 – View of the drill rig set up at the location of Boring B-1.



Photo 3 – View of the loose to medium dense, fine-grained sand recovered between 10 to 11.5 feet depth in Boring B-1.



Photo 4 – View of the dense, silty sand recovered between 25 to 26.5 feet depth in Boring B-1.



Photo 5 – View of the dense, medium to coarse-grained sand with shell fragments recovered between 30 to 31.5 feet depth in Boring B-1.



Photo 6 – View of the soft/loose, clayey, silty sand with decaying wood fragments recovered between 37 to 38.5 feet depth in Boring B-1.



Photo 7 – View of the very dense silty sand with decaying wood fragments recovered between 50 to 51.5 feet depth in Boring B-1.



Photo 8 – Close-up view of the very dense, fine-grained, clean sand recovered between 60 to 61.5 feet depth in Boring B-1.

Project #Y234676B

Appendix B  
- Boring Logs -

## BORING LOG EXPLANATION

<b>UNIFIED SOIL CLASSIFICATION SYSTEM (USCS), ASTM D2487</b>			
MAJOR DIVISIONS		GROUP SYMBOL*	GROUP NAME
COARSE-GRAINED SOILS	GRAVELS	GW	Well-graded gravel
		GP	Poorly-graded gravel
		GM	Silty gravel
		GC	Clayey gravel
	SANDS	SW	Well-graded sand
		SP	Poorly-graded sand
		SM	Silty sand
		SC	Clayey sand
FINE-GRAINED SOILS	SILTS AND CLAYS Liquid Limit Less than 50	ML	Silt with low plasticity
		CL	Clay with low plasticity
		OL	Organic silt or organic clay with low plasticity
	SILTS AND CLAYS Liquid Limit 50 or more	MH	Silt with high plasticity
		CH	Clay with high plasticity
		OH	Organic silt or organic clay with high plasticity
HIGHLY ORGANIC SOILS		PT	Peat, Muck, and other highly organic soils.

\* NOTE: the symbol RK (not within the USCS system) is used in our logs to denote rock materials.

### SAMPLE TYPE

SPT = Standard Penetration Test and Split-Barrel Sampler (ASTM D1586); 1 3/8-inch I.D.

2.5" = Modified 2.5-inch I.D. Split-Barrel Sampler.

Shelby = Thin-Walled Tube Sampler (ASTM D1587); 3-inch O.D.

### Sampling Interval



= No sample attempted



= Location of retrieved sample.



= Location where sample was attempted with no recovery.

### Standard Penetration Test (SPT)

Blows per 6" = Number of blows required to drive SPT sampler 6 inches using a 140 Lb. hammer dropped from a height of 30 inches (recorded in three 6" intervals).

N = Standard Penetration Resistance: Number of blows (N) required to drive SPT sampler 12 inches using a 140 Lb. hammer dropped from a height of 30 inches (ASTM D1586).

P = Indicates that SPT sampler was pushed 6 inches with only the weight of the hammer or drill stem (N = 0)



<b>Location:</b> Neskowin, Oregon		<b>Job Name:</b> Breakers Condo		<b>Project #:</b> Y234676B	
<b>Drilling Company:</b> Western States		<b>Driller:</b> Shane		<b>Boring #:</b> B1	
<b>Drill Rig:</b> CME-75	Solid Auger 4"	Hollow Auger	<b>Rotary Wash</b>	Sheet 1 of 4	
<b>Sampler Type:</b> 2.5" Split Barrel		2.8" Shelby Tube		<b>SPT</b>	
<b>Drive Wt.</b> 140 Lbs		<b>Fall:</b> 30 In.		<b>Drilling Time</b>	
<b>Water Level</b>		<b>Depth (ft.)</b>		<b>Time</b>	<b>Date</b>
		~12.5 to ~15		<b>Start</b>	<b>Finish</b>
				<b>Time:</b> ~10am	<b>Time:</b> ~1pm
				<b>Date:</b> 2/15/2024	<b>Date:</b> 2/15/2024
<b>Field Personnel:</b> M. Bordial			<b>Casing Depth:</b> (Ft.)		<b>Ground Elevation:</b> ~26 (Ft.)

Blows per 6"	N	Sample Type	Depth (Ft.)	USCS	Description		
			0	FILL	Loose fill sand in area of previous foundation.		
3	3	4	7	SPT	2.5	SP	Sand; medium brown with dark grains, moist, loose, medium grained. ~8" recovered in split spoon.
4	4	6	10	SPT	5	SP	Sand; medium brown, moist, loose to medium dense, medium grained. ~8" recovered in split spoon.
4	5	6	11	SPT	7.5	SP	Sand; medium brown, moist, loose to medium dense, medium grained. ~8" recovered in split spoon.
5	5	5	10	SPT	10	SP	Sand; gray-brown, moist, loose to medium dense, fine grained. ~6.5" recovered in split spoon.
6	8	10	18	SPT	12.5	SP	Sand; medium brown with dark grains, wet, medium dense, fine to medium grained. ~9" recovered in split spoon.
							Groundwater
10	11	12	23	SPT	15	SM	Silty Sand; brown with dark grains, wet to saturated, medium dense, silt to fine grained sand.
9	14	18	32	SPT	17.5	SP	Sand; medium brown, wet to saturated, dense, medium grained. ~10" recovered in split spoon.

<b>Location:</b> Neskowin, Oregon		<b>Job Name:</b> Breakers Condo		<b>Project #:</b> Y234676B	
<b>Drilling Company:</b> Western States		<b>Driller:</b> Shane		<b>Boring #:</b> B1	
<b>Drill Rig:</b> CME-75	Solid Auger 4"	Hollow Auger	<b>Rotary Wash</b>	Sheet 2 of 4	
<b>Sampler Type:</b> 2.5" Split Barrel		2.8" Shelby Tube		<b>SPT</b>	
<b>Drive Wt.</b> 140 Lbs		<b>Fall:</b> 30 In.		<b>Drilling Time</b>	
<b>Water Level</b>		<b>Depth (ft.)</b>		<b>Time</b>	
		~12.5 to ~15		<b>Start</b>	
				<b>Finish</b>	
				<b>Time: ~10am</b>	
				<b>Time: ~1pm</b>	
				<b>Date: 2/15/2024</b>	
				<b>Date: 2/15/2024</b>	
<b>Field Personnel:</b> M. Bordal			<b>Casing Depth:</b> (Ft.)		<b>Ground Elevation:</b> ~26 (Ft.)

Blows per 6"				N	Sample Type	Depth (Ft.)	USCS	Description
10	14	18	32	SPT	20	SP	Sand; brown with dark minerals, wet to saturated, dense. ~9" recovered in split spoon.	
					22.5			
10	15	16	31	SPT	25	SM	Silty Sand; brown, wet to saturated, dense. Silt to medium grained with a few ~1/4" pebbles and very coarse grains. ~10" recovered in split spoon.	
					27.5			
				GRAB		GW-Shells	Pebbles and Shell fragments coming up in drilling fluid screen	
15	17	20	37	SPT	30	SW	Sand; dark gray, wet to saturated, dense. Medium to coarse grained. With shell fragments and rock fragments. ~10" recovered in split spoon.	
					32.5			
				GRAB	35	PT	Peat, fine organics, and shell fragments. Sulfur Smell	
2	3	4	7	SPT	37.5	PT/SM	Organic Rich Clayey Silt and Silty Sand; dark gray, moist, soft/loose. Decaying wood debris and organics. ~15" recovered in split spoon.	

<b>Location:</b> Neskowin, Oregon		<b>Job Name:</b> Breakers Condo		<b>Project #:</b> Y234676B	
<b>Drilling Company:</b> Western States		<b>Driller:</b> Shane		<b>Boring #:</b> B1	
<b>Drill Rig:</b> CME-75	Solid Auger 4"	Hollow Auger	<b>Rotary Wash</b>	<b>Sheet</b> <u>3</u> <b>of</b> <u>4</u>	
<b>Sampler Type:</b>	2.5" Split Barrel	2.8" Shelby Tube	<b>SPT</b>	<b>Drilling Time</b>	
<b>Drive Wt.</b>	140 Lbs	<b>Fall:</b>	30 In.	<b>Start</b>	<b>Finish</b>
<b>Water Level</b>	<b>Depth (ft.)</b>	<b>Time</b>	<b>Date</b>	<b>Time:</b> ~10am	<b>Time:</b> ~1pm
	~12.5 to ~15				
				<b>Date:</b> 2/15/2024	<b>Date:</b> 2/15/2024

<b>Field Personnel:</b>	M. Bordal	<b>Casing Depth:</b>	(Ft.)	<b>Ground Elevation:</b>	~26 (Ft.)
-------------------------	-----------	----------------------	-------	--------------------------	-----------

Blows per 6"				N	Sample Type	Depth (Ft.)	USCS	Description
5	10	12	22	SPT	40	SM	Silty Sand; dark gray, wet to saturated, loose/soft. Silt to fine sand. No sulfur smell, fine organics, and ~1" wood fragment. ~15" recovered in split spoon.	
					42.5			
						PT	Wood debris, organics, clayey peat coming up on drilling fluid	
15	21	18	39	SPT	45	SM	Silty Sand; dark gray, wet to saturated, dense. Silt to fine sand. No organics. ~13" recovered in split spoon.	
					47.5			
12	20	28	48	SPT	50	SM	Silty Sand; dark gray, wet to saturated, dense. Silt to fine sand. Wood fragment near bottom of sampler. ~11" recovered in split	
					52.5			
35	50		50+	SPT	55	SP	Sand; medium gray, wet to saturated, very dense. Fine grained, no silt or organics. ~10" recovered in split spoon.	

Project #Y234676B

Appendix C  
- Liquefaction Analysis -

# LIQUEFACTION ANALYSIS

Y234676B

Hole No.=B-1 Water Depth=12.5 ft Surface Elev.=26

Magnitude=8.8  
Acceleration=.77g

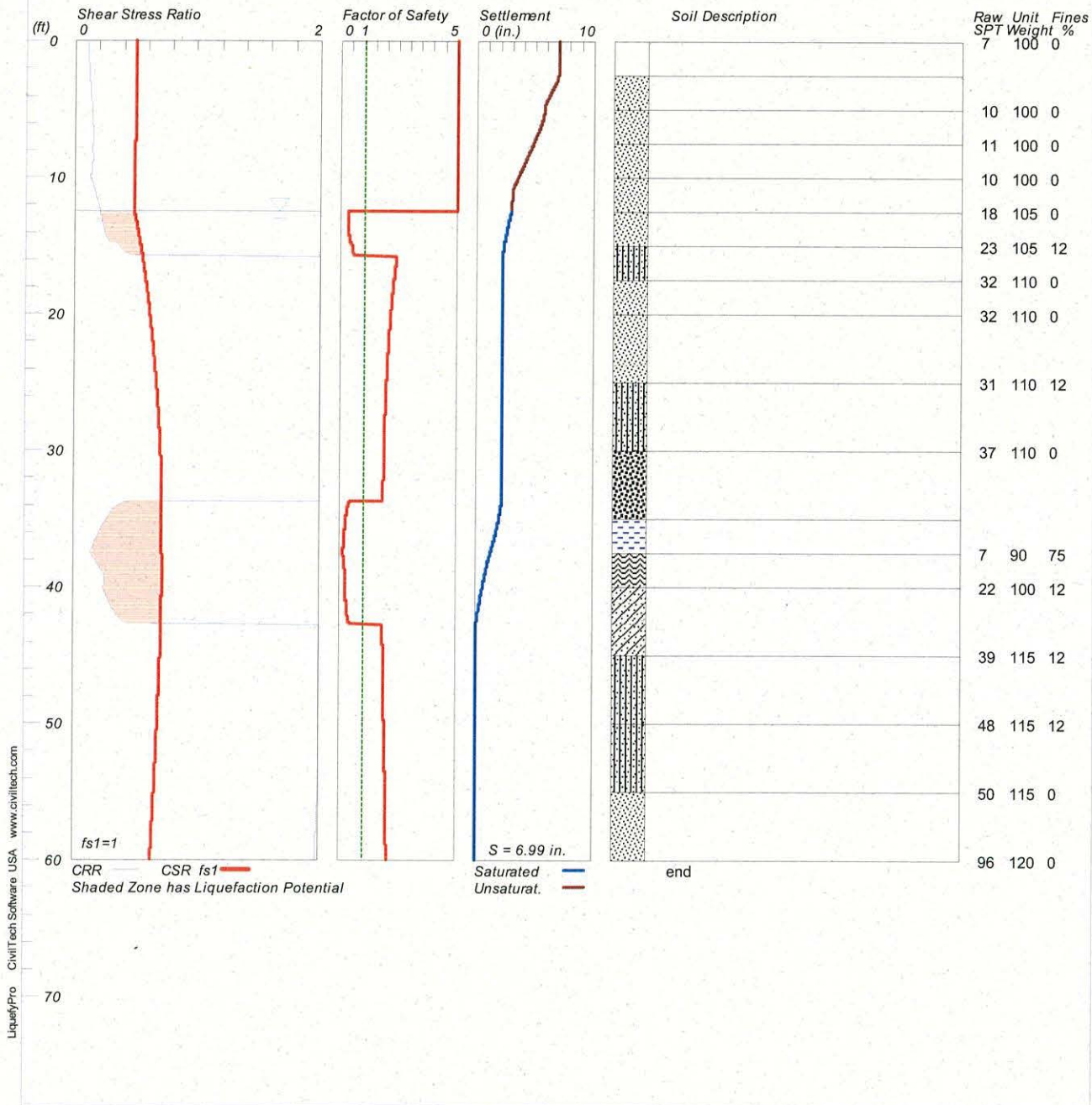

LiquefyPro CivilTech Software USA www.civilttech.com

Project #Y234676B

Appendix D  
- Pile Analysis -

Project #Y234676B

- 8-inch Micropile -

For uplift and compression, one  
no-friction steel casing section  
and one high pressure grouted  
section.

### FOUNDATION PROFILE & SOIL CONDITIONS

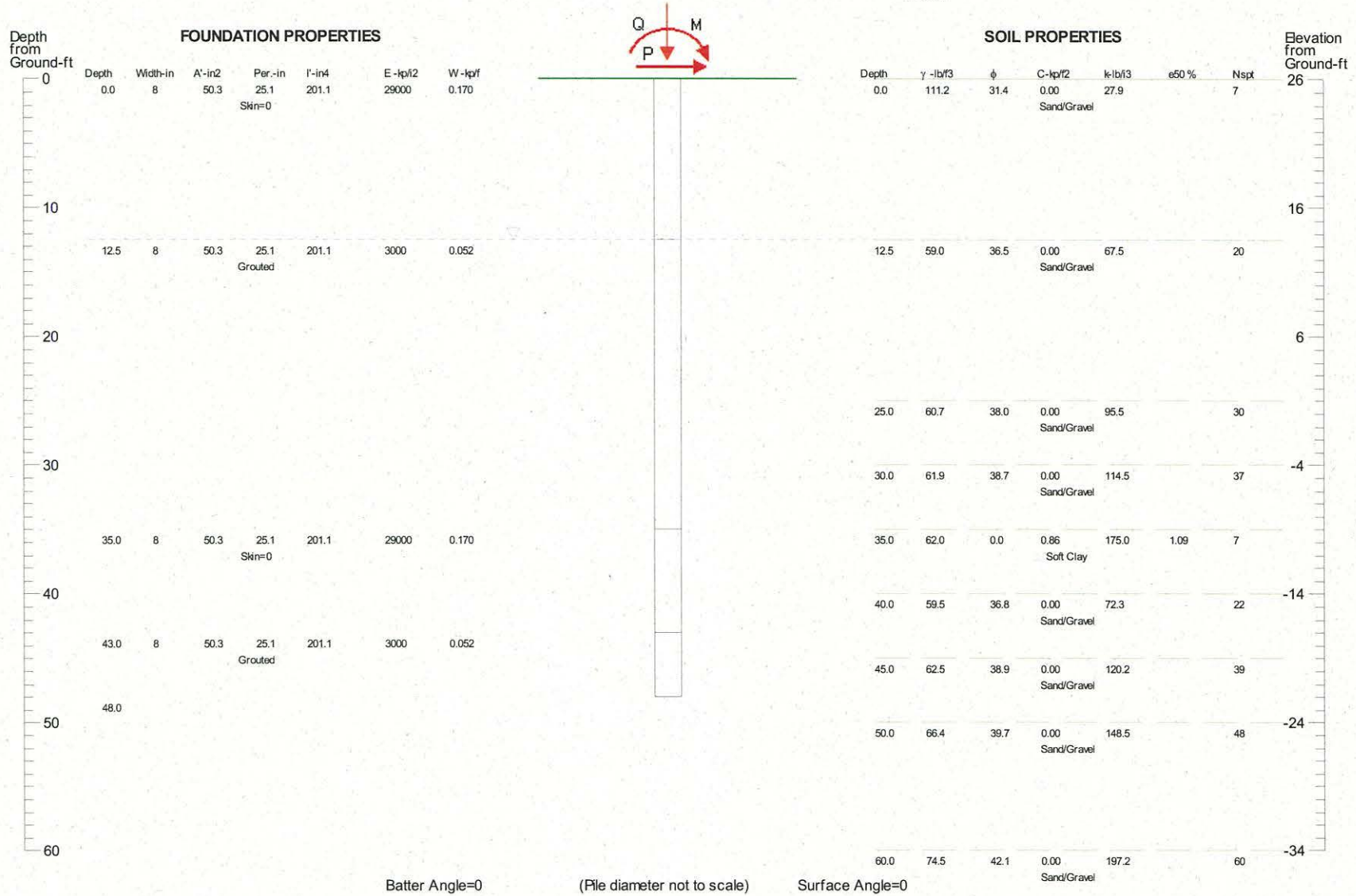

Batter Angle=0

(Pile diameter not to scale)

Surface Angle=0



**CivilTech  
Software**

**Y234676B  
Breakers 8inch**

Figure 1



# VERTICAL ANALYSIS

Figure 1

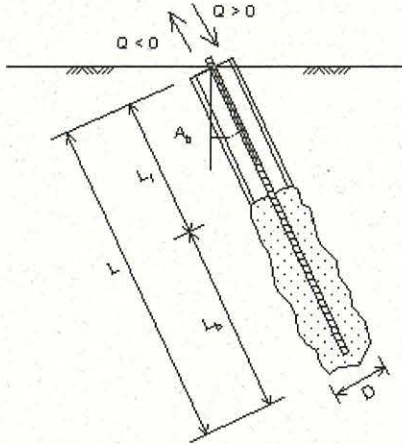

Micropile (MiniPile)

**Loads:**

Load Factor for Vertical Loads= 1.0  
 Load Factor for Lateral Loads= 1.0  
 Loads Supported by Pile Cap= 0 %  
 Shear Condition: Static

Vertical Load, Q= 25.0 -kp  
 Shear Load, P= 0.0 -kp  
 Moment, M= 0.0 -kp-f

**Profile:**

Pile Length, L= 48.0 -ft  
 Top Height, H= 0 -ft  
 Slope Angle, As= 0  
 Batter Angle, Ab= 0

**Soil Data:**

Depth -ft	Gamma -lb/f3	Phi	C -kp/f2	K -lb/f3	e50 or Dr %	Nspt
0	111.2	31.4	0.00	27.9	27.34	7
12.5	59.0	36.5	0.00	67.5	54.06	20
25	60.7	38.0	0.00	95.5	65.80	30
30	61.9	38.7	0.00	114.5	72.63	37
35	62.0	0.0	0.86	175.0	1.09	7
40	59.5	36.8	0.00	72.3	56.25	22
45	62.5	38.9	0.00	120.2	74.55	39
50	66.4	39.7	0.00	148.5	83.29	48
60	74.5	42.1	0.00	197.2	95.94	60

**Pile Data:**

Depth -ft	Width -in	Area -in2	Per. -in	I -in4	E -kp/f2	Weight -kp/f
0.0	8	50.3	25.1	201.1	29000	0.170
12.5	8	50.3	25.1	201.1	3000	0.052
25	8	50.3	25.1	201.1	29000	0.170
30	8	50.3	25.1	201.1	3000	0.052
35	8	50.3	25.1	201.1		
40	8	50.3	25.1	201.1		
45	8	50.3	25.1	201.1		
50	8	50.3	25.1	201.1		
60	8	50.3	25.1	201.1		

**Vertical capacity:**

Weight above Ground= 0.00 Total Weight= 4.15-kp \*Soil Weight is not included  
 Side Resistance (Down)= 95.263-kp Side Resistance (Up)= 95.263-kp  
 Tip Resistance (Down)= 0.000-kp Tip Resistance (Up)= 0.000-kp  
 Total Ultimate Capacity (Down)= 95.263-kp Total Ultimate Capacity (Up)= 99.415-kp  
 Total Allowable Capacity (Down)= 38.105-kp Total Allowable Capacity (Up)= 39.766-kp  
 OK! Qallow > Q

**Settlement Calculation:**

At Q= 25.00-kp Settlement= 0.02702-in  
 At Xallow= 1.00-in Qallow= 99999.00000-kp

Note: If the program cannot find a result or the result exceeds the upper limit. The result will be displayed as 99999.

### SOIL STRESS, SIDE RESISTANCE, & AXIAL FORCE vs DEPTH Based on Ultimate Load Condition

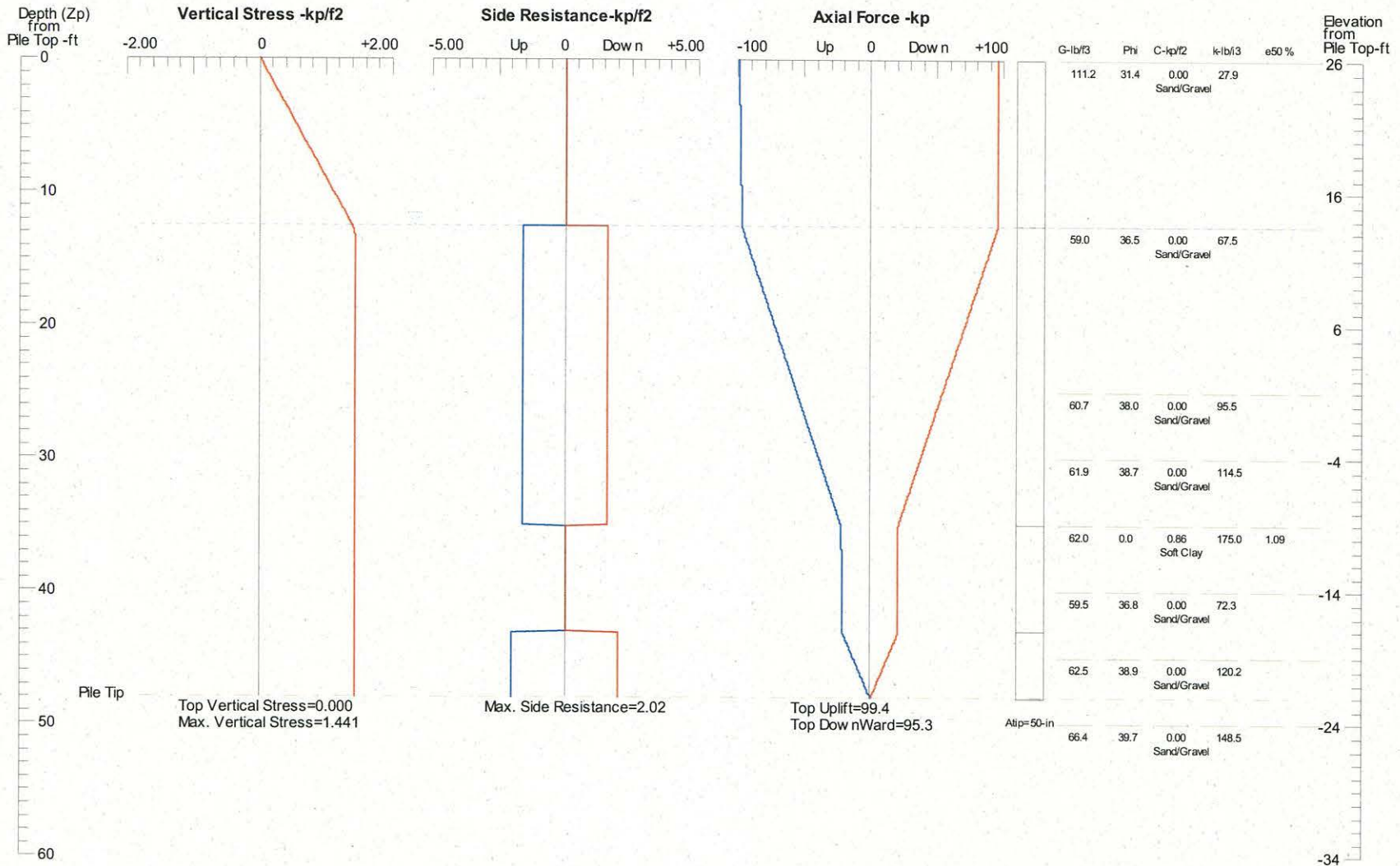

Y234676B  
Breakers 8inch

Figure 1

## ALLOWABLE CAPACITY vs FOUNDATION DEPTH

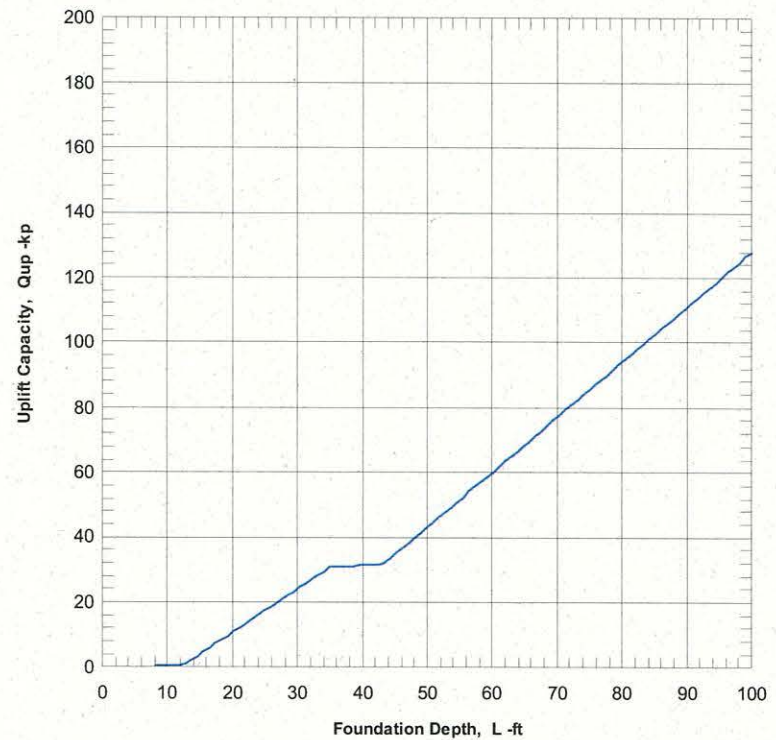
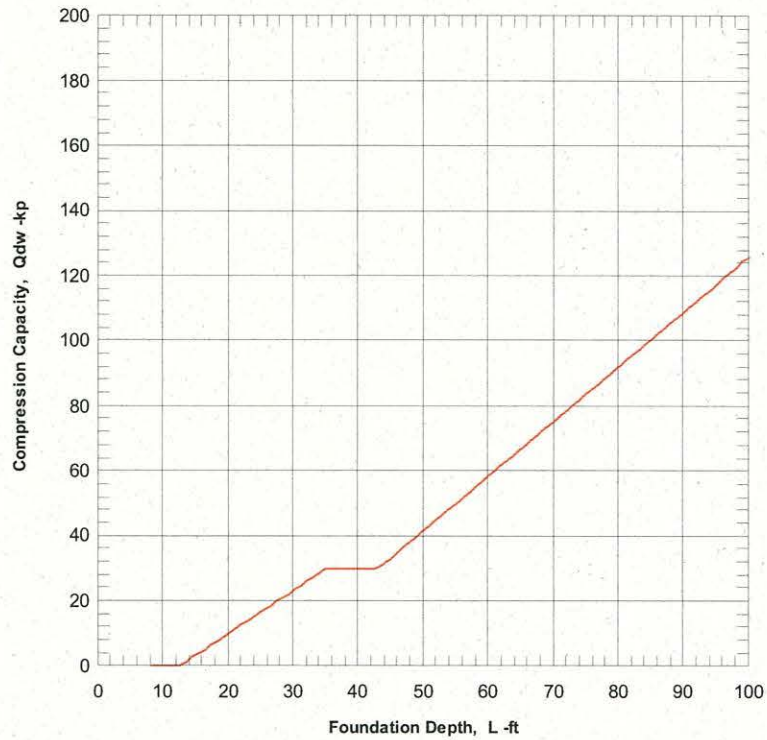

### Vertical Load vs. Settlement

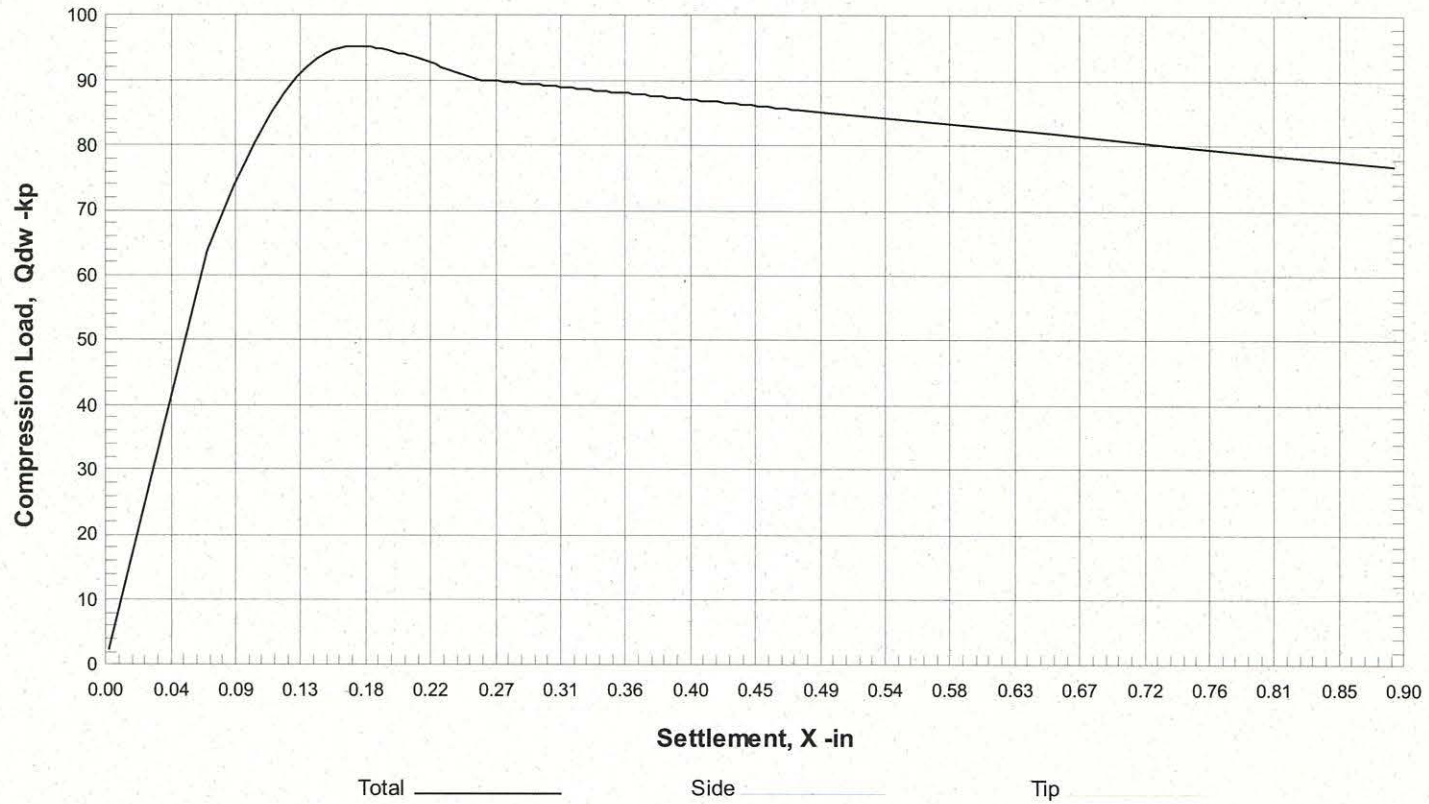

Project #Y234676B

- 10-inch Micropile -

For uplift and compression, one no-friction steel casing section and one high pressure grouted section.

### FOUNDATION PROFILE & SOIL CONDITIONS

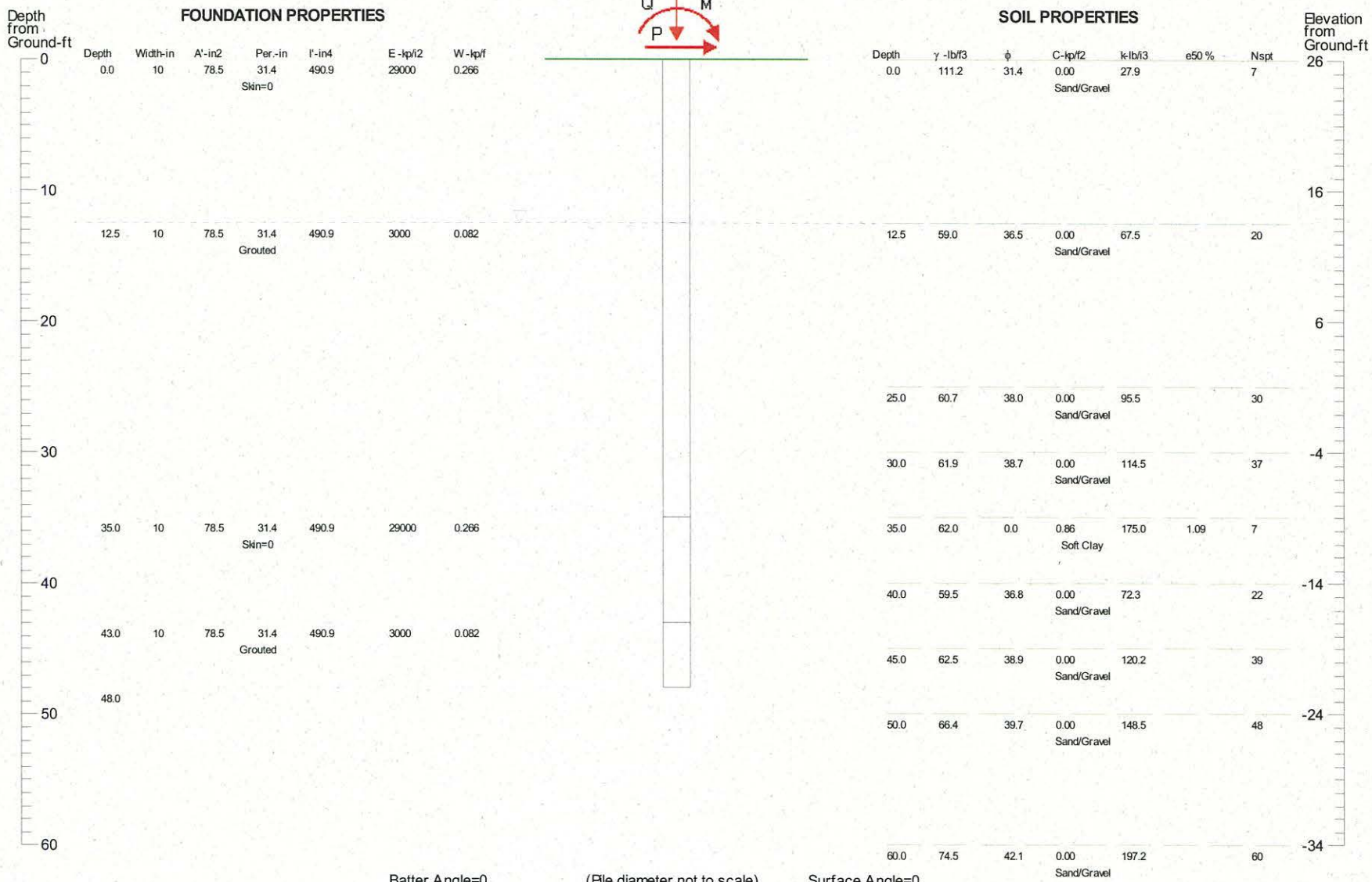

Batter Angle=0

(Pile diameter not to scale)

Surface Angle=0



**CivilTech Software**

**Y234676B  
Breakers 10inch**

Figure 1

# VERTICAL ANALYSIS

Figure 1

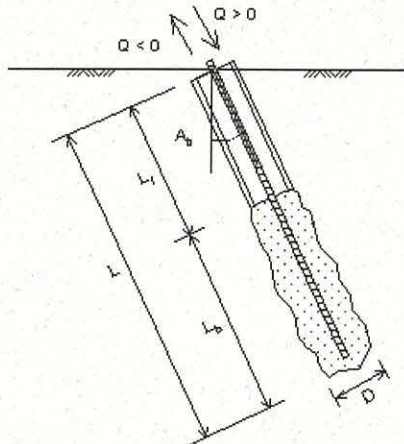

Micropile (MiniPile)

**Loads:**

Load Factor for Vertical Loads= 1.0  
 Load Factor for Lateral Loads= 1.0  
 Loads Supported by Pile Cap= 0 %  
 Shear Condition: Static

Vertical Load, Q= 25.0 -kp  
 Shear Load, P= 0.0 -kp  
 Moment, M= 0.0 -kp-f

**Profile:**

Pile Length, L= 48.0 -ft  
 Top Height, H= 0 -ft  
 Slope Angle, As= 0  
 Batter Angle, Ab= 0

**Soil Data:**

Depth -ft	Gamma -lb/f3	Phi	C -kp/f2	K -lb/f3	e50 or Dr %	Nspt
0	111.2	31.4	0.00	27.9	27.34	7
12.5	59.0	36.5	0.00	67.5	54.06	20
25	60.7	38.0	0.00	95.5	65.80	30
30	61.9	38.7	0.00	114.5	72.63	37
35	62.0	0.0	0.86	175.0	1.09	7
40	59.5	36.8	0.00	72.3	56.25	22
45	62.5	38.9	0.00	120.2	74.55	39
50	66.4	39.7	0.00	148.5	83.29	48
60	74.5	42.1	0.00	197.2	95.94	60

**Pile Data:**

Depth -ft	Width -in	Area -in2	Per. -in	I -in4	E -kp/f2	Weight -kp/f
0.0	10	78.5	31.4	490.9	29000	0.266
12.5	10	78.5	31.4	490.9	3000	0.082
35.0	10	78.5	31.4	490.9	29000	0.266
43.0	10	78.5	31.4	490.9	3000	0.082
48.0						

**Vertical capacity:**

Weight above Ground= 0.00 Total Weight= 6.52-kp \*Soil Weight is not included  
 Side Resistance (Down)= 119.174-kp Side Resistance (Up)= 119.175-kp  
 Tip Resistance (Down)= 0.000-kp Tip Resistance (Up)= 0.000-kp  
 Total Ultimate Capacity (Down)= 119.174-kp Total Ultimate Capacity (Up)= 125.691-kp  
 Total Allowable Capacity (Down)= 47.670-kp Total Allowable Capacity (Up)= 50.276-kp  
 OK! Qallow > Q

**Settlement Calculation:**

At Q= 25.00-kp Settlement= 0.01932-in  
 At Xallow= 1.00-in Qallow= 97.14198-kp

Note: If the program cannot find a result or the result exceeds the upper limit. The result will be displayed as 99999.



Y234676B  
 Breakers 10inch

### SOIL STRESS, SIDE RESISTANCE, & AXIAL FORCE vs DEPTH Based on Ultimate Load Condition

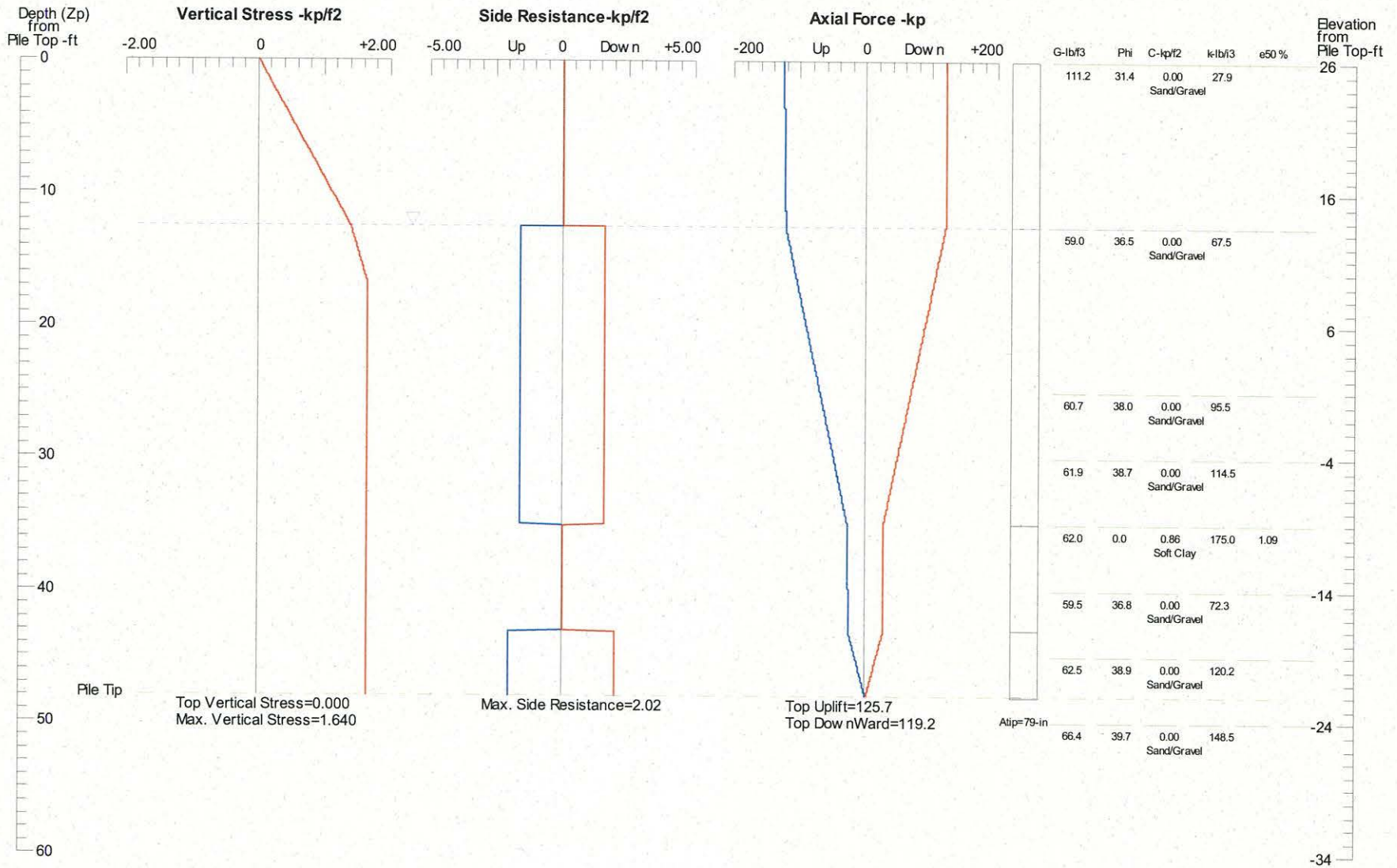

Y234676B  
Breakers 10inch

Figure 1



### ALLOWABLE CAPACITY vs FOUNDATION DEPTH

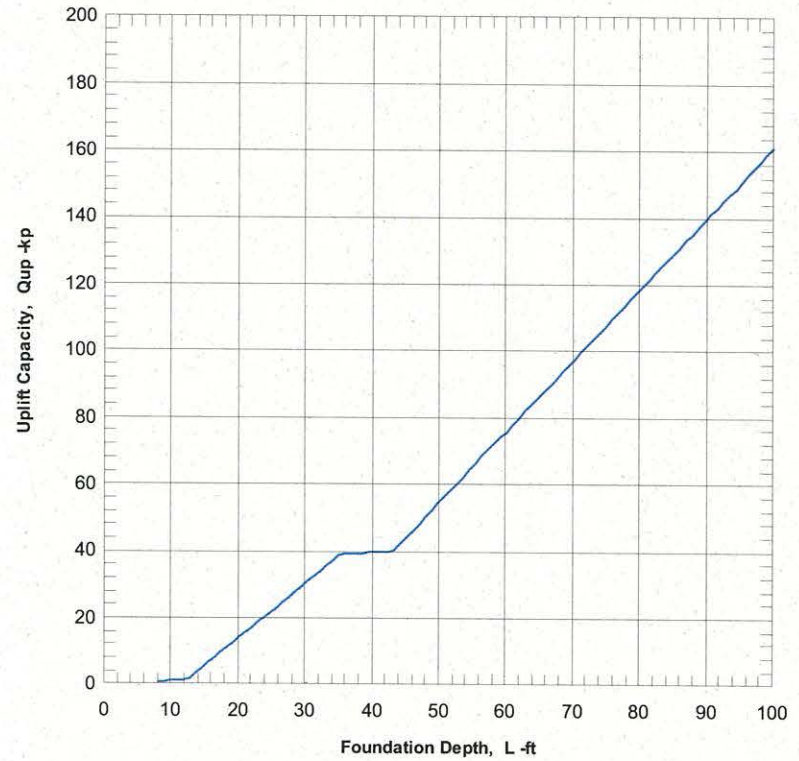
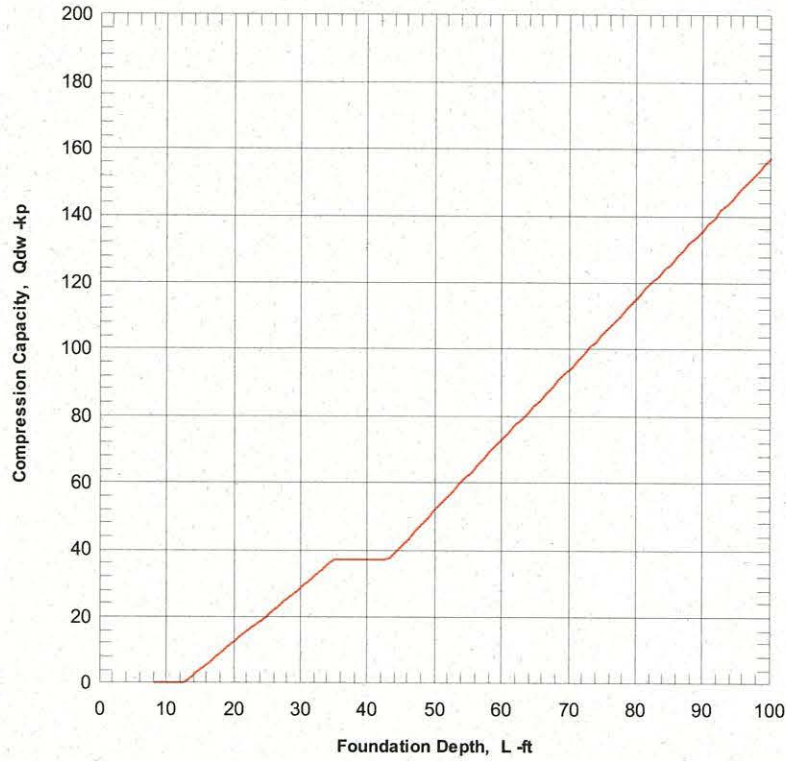

### Vertical Load vs. Settlement

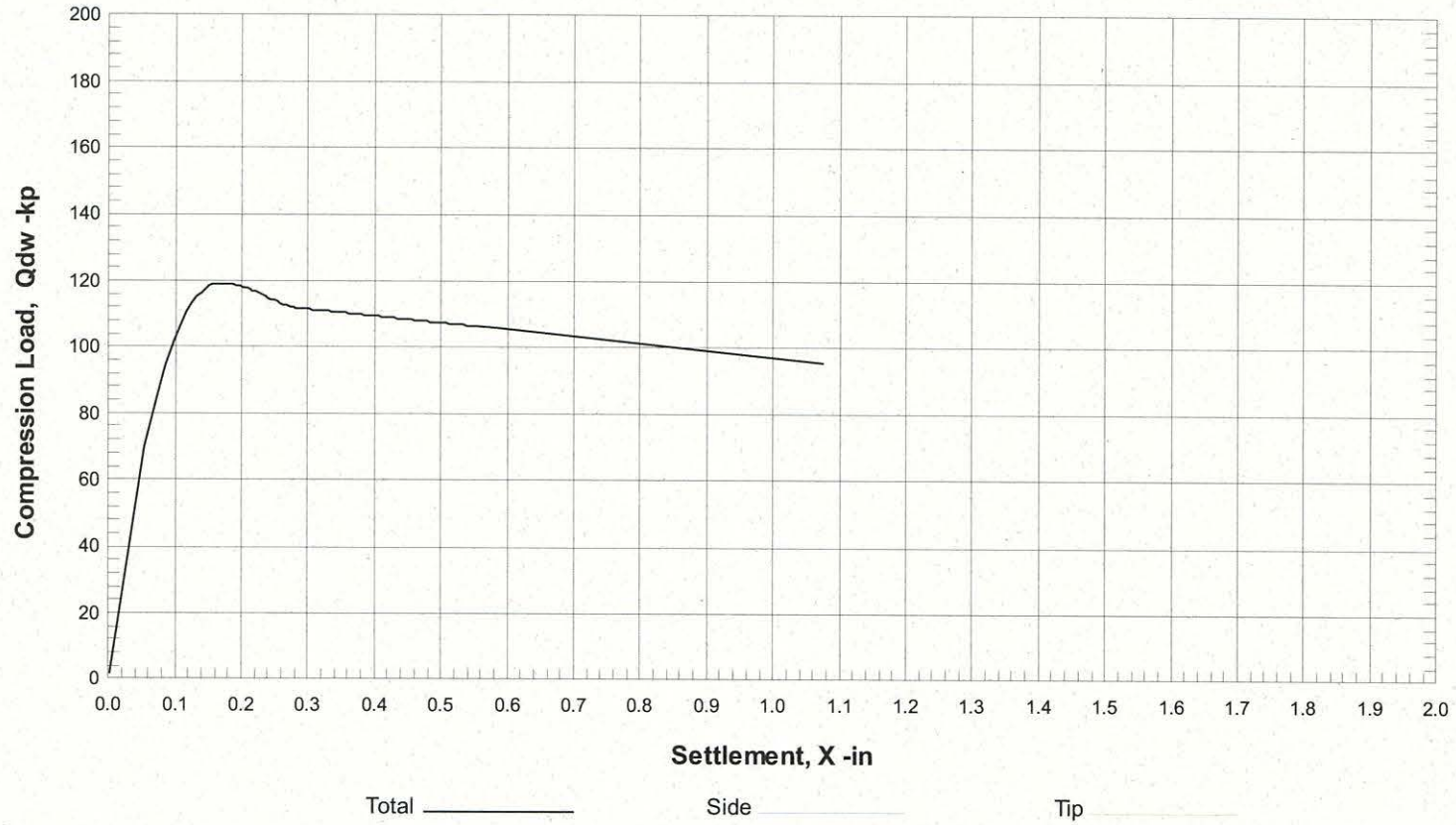

Project #Y234676B

Appendix E  
- Checklist of Recommended Plan Reviews and Site Observations -

Project #Y234676B

APPENDIX E  
Checklist of Recommended Plan Reviews and Site Observations  
To Be Completed by a Representative of H.G. Schlicker & Associates, Inc.

Item No.	Date Done	Procedure	Timing
1*		Review site development, foundation, drainage, grading and erosion control plans.	Prior to permitting and construction.
2*		Observe Pile installation and testing operations.	During installation. **
3*		Summary Site Observation Visit	After construction before occupancy**

\* There will be additional charges for these services.

\*\* Please provide us with at least 5 days' notice prior to all site observations.

**Geologic Hazards Investigation  
Tax Lot 92411, Map 5S-11W-25CB Supp. Map No. 2  
Lot-Unit 11, 48060 Breakers Boulevard  
Neskowin, Tillamook County, Oregon**

**Prepared for:  
Breakers Condominium  
Attn: Glenn Garrett, HOA President  
16476 NW Racely Court  
Portland, Oregon 97229**

Project #Y234676

May 23, 2023



**H.G. Schlicker & Associates, Inc.**

607 Main Street, Suite 200 · Oregon City, Oregon 97045  
(503) 655-8113 · FAX (503) 655-8173

Project #Y234676

May 23, 2023

**To: Breakers Condominium  
Attn: Glenn Garrett, HOA President  
16476 NW Racely Court  
Portland, Oregon 97229**

**Subject: Geologic Hazards Investigation  
Tax Lot 92411, Map 5S-11W-25CB Supp. Map No. 2  
Lot-Unit 11, 48060 Breakers Boulevard  
Neskowin, Tillamook County, Oregon**

**Dear Mr. Garrett:**

The accompanying report presents the results of our geologic hazards investigation for the above subject site.

After you have reviewed our report, we would be pleased to discuss it and to answer any questions you might have.

This opportunity to be of service is sincerely appreciated. If we can be of any further assistance, please contact us.

**H.G. SCHLICKER & ASSOCIATES, INC.**

Adam M. Large, MSc, RG, CEG  
President/Principal Engineering Geologist

AML:mgb

**TABLE OF CONTENTS**

	<u>Page</u>
<b>1.0 Introduction.....</b>	<b>1</b>
<b>2.0 Site Description .....</b>	<b>1</b>
<b>2.1 The history of the site and surrounding areas, such as previous riprap or dune grading permits, erosion events, exposed trees on the beach, or other relevant local knowledge of the site.....</b>	<b>2</b>
<b>2.2 Topography, including elevations and slopes on the property itself.....</b>	<b>2</b>
<b>2.3 Vegetation cover.....</b>	<b>2</b>
<b>2.4 Subsurface materials – the nature of the rocks and soils.....</b>	<b>3</b>
<b>2.5 Conditions of the seaward front of the property, particularly for sites having a sea cliff .</b>	<b>3</b>
<b>2.6 Presence of drift logs or other flotsam on or within the property.....</b>	<b>3</b>
<b>2.7 Description of streams or other drainage that might influence erosion or locally reduce the level of the beach .....</b>	<b>3</b>
<b>2.8 Proximity of nearby headlands that might block the long shore movement of beach sediments, thereby affecting the level of the beach in front of the property</b>	<b>3</b>
<b>2.9 Description of any shore protection structures that may exist on the property or on nearby properties.....</b>	<b>4</b>
<b>2.10 Presence of pathways or stairs from the property to the beach .....</b>	<b>4</b>

**TABLE OF CONTENTS (continued)**

	<u>Page</u>
2.11 Existing human impacts on the site, particularly any that might alter the resistance to wave attack.....	4
3.0 Description of the Fronting Beach.....	4
3.1 Average widths of the beach during the summer and winter.....	4
3.2 Median grain size of beach sediment .....	4
3.3 Average beach slopes during the summer and winter.....	4
3.4 Elevations above mean sea level of the beach at the seaward edge of the property during summer and winter .....	5
3.5 Presence of rip currents and rip embayments that can locally reduce the elevation of the fronting beach.....	5
3.6 Presence of rock outcrops and sea stacks, both offshore and within the beach zone .....	5
3.7 Information regarding the depth of beach sand down to bedrock at the seaward edge of the property .....	5
4.0 Geologic Hazards Analysis.....	5
4.1 Subsurface Materials.....	6
4.2 Geologic Structures.....	6
4.3 Slopes.....	7



**TABLE OF CONTENTS (continued)**

	<u>Page</u>
4.4 Orientation of Bedding Planes in Relation to the Dip of the Surface Slope.....	7
4.5 Site Surface Water Drainage Patterns.....	7
4.6 Dune Stability and Erosion .....	7
4.7 Regional Seismic Hazards .....	8
4.8 Flooding Hazards .....	10
4.9 Climate Change.....	10
4.10 Analyses of Erosion and Flooding Potential.....	11
4.11 Assessment of Potential Reactions to Erosion episodes.....	13
5.0 Conclusions and Preliminary Recommendations for Further Work.....	13
6.0 Limitations.....	15
7.0 Disclosure.....	15
8.0 References Cited.....	16

**FIGURES**

- Figure 1 – Location Map
- Figure 2 – Plat Map
- Figure 3 – Site Topographic Map
- Figure 4 – Slope Profile A-A'

**APPENDICES**

- Appendix A – Site Photographs



# H.G. Schlicker & Associates, Inc.

607 Main Street, Suite 200 · Oregon City, Oregon 97045  
(503) 655-8113 · FAX (503) 655-8173

Project #Y234676

May 23, 2023

**To: Breakers Condominium  
Attn: Glenn Garrett, HOA President  
16476 NW Racely Court  
Portland, Oregon 97229**

**Subject: Geologic Hazards Investigation  
Tax Lot 92411, Map 5S-11W-25CB Supp. Map No. 2  
Lot-Unit 11, 48060 Breakers Boulevard  
Neskowin, Tillamook County, Oregon**

**Dear Mr. Garrett:**

## **1.0 Introduction**

At your request and authorization, a representative of H.G. Schlicker and Associates, Inc. (HGSA) visited the subject site on March 31, 2023, to complete a geologic hazards investigation of Tax Lot 92411, Map 5S-11W-25CB Supp. Map No. 2, Lot-Unit 11, 48060 Breakers Boulevard, Neskowin, Tillamook County, Oregon (Figures 1 and 2; Appendix A). Reportedly, the existing residential building was severely damaged by a structural fire. It is our understanding that you are working with a contractor and the owner's representative and plan to demolish the existing damaged structure and build a new residential building in its place. Reportedly, the proposed development will be considered a new development, new construction or a substantial improvement; however, we defer to the county and city of Neskowin to make this determination.

This report addresses the geologic hazards at the site with respect to the proposed development. The scope of our work consisted of a site visit, site observations and measurements, a slope profile, a limited review of the geologic literature, interpretation of topographic maps, lidar and stereo aerial photographs, and preparation of this report of our findings, conclusions and preliminary recommendations for further work.

## **2.0 Site Description**

The subject site consists of Tax Lot 92411, Map 5S-11W-25CB Supp. Map No. 2, which is approximately 20 feet wide and 30 feet deep. The rectangular-shaped lot is located on a

younger stabilized dune at the Breakers Condominiums in the community of Neskowin, Oregon (Figure 1). The site is one of eleven condominium tax lots located within Tax Lot 92412, Map 5S-11W-25CB, which encompasses the greater area of the Breakers Condominiums (Figure 2).

The subject site is occupied by a fire-damaged residential structure and attached deck. An oceanfront protective structure (riprap revetment) is located on the dune slope approximately 105 feet west of the site; this revetment is contiguous with other revetments to the north and south (Appendix A). The condominium property surrounding the site is bounded to the west by the beach and the Pacific Ocean, to the north by Mt. Angel Avenue, to its east by Breakers Boulevard, and to its south by Sheridan Avenue.

### **2.1 The history of the site and surrounding areas, such as previous riprap or dune grading permits, erosion events, exposed trees on the beach, or other relevant local knowledge of the site**

According to Tillamook County records, the existing one and ½ story building was built in 1971 as part of the Breaker Condominium development. The condominium property is occupied by 11 detached residential units on individual lots within a larger parcel with a detached building in the southeast corner. The units, including the subject site, share an asphalt parking area accessed off Breakers Blvd. The subject building and attached deck appear to completely occupy the tax lot of the subject site. Reportedly, a fire recently severely damaged the building (Appendix A). According to a review of a 1967 aerial photograph, the area of the site was previously occupied by an undeveloped dune. Based on this photo, a detached building appears to occupy the southeast of the site at that time.

The site lies along an area that has been hardened with riprap revetment for hundreds of feet to the north and south. Most of this hardening has been constructed during and following the severe El Niño and La Niña events of the mid-to-late 1990s. Much of this riprap has needed repair of varying degree throughout the years.

### **2.2 Topography, including elevations and slopes on the property itself**

The site is located on the western portion of a younger stabilized dune. Elevation at the site is approximately 26 feet (NAVD 88). The area of the site is generally flat but appears to have been subject to prior grading activities (Figures 3 and 4; Appendix A).

### **2.3 Vegetation cover**

The subject site appears to be completely occupied by the existing building. The vegetation in the area of the site consists of lawn grass, beach grass and a few shore pine along the road.

#### **2.4 Subsurface materials – the nature of the rocks and soils**

Subsurface materials are discussed in detail in Section 4.1.

#### **2.5 Conditions of the seaward front of the property**

The property's western boundary (seaward front) is located approximately 105 feet east of the revetment in the western portion of a younger-developed dune. The general area of the site is densely developed, with existing homes with varying amounts of vegetation.

At The Breakers Condominiums, the revetment is approximately 20 feet high and generally slopes at 29 to 31 degrees. The armor stone generally varies from 4 to 7 feet in diameter along the mid and lower slope and 3 to 6 feet in diameter along the upper slope. The revetment is composed of angular basalt quarry stone from various sources. Some of the rock consists of volcanic breccias and agglomerates, including pillow basalts. Much of the volcanic breccia and agglomerate is fractured and can break into smaller pieces. Some of the revetment is composed of better quality, harder, fine-grained basalt of more durable character. We believe the better quality rock was primarily placed during repairs.

Reportedly, the revetment lacks a geotextile filter fabric beneath it to prevent the piping of sand from behind the revetment out through it (sand bleed through). Unfortunately, sand piping can occur anytime water levels are above the toe of the revetment, not just during storm conditions.

#### **2.6 Presence of drift logs or other flotsam on or within the property**

During our site visit, we did not observe drift logs or flotsam on the beach to the west of the property. However, a small log was wedged in the riprap boulders in the lower portion of the revetment west of the site.

#### **2.7 Description of streams or other drainage that might influence erosion or locally reduce the level of the beach**

Neskowin Creek discharges onto the beach approximately 0.5 mile south of the site (Figure 1). Historical satellite imagery from Google Earth indicates that although Neskowin Creek's stream channel meanders approximately 500 feet north and south on the beach, the stream generally enters the ocean near the east side of proposal rock and does not appear to influence the level of the beach west of the subject site.

#### **2.8 Proximity of nearby headlands that might block the long shore movement of beach sediments, thereby affecting the level of the beach in front of the property**

The site is located approximately 1 mile north of the Cascade Head headlands and approximately 7.5 miles south of Cape Kiwanda. Proposal Rock, located approximately 0.5 miles south of the site, can be considered the nearest headland and does not appear to affect the subject site substantially.

### **2.9 Description of any shore protection structures that may exist on the property or on nearby properties**

An existing riprap revetment is present approximately 105 feet west of the subject site and is connected to other oceanfront revetments, which extend for hundreds of feet to the south along Neskowin Beach. The unimproved beach access ramp at the western end of Mt. Angel Avenue is not occupied by an oceanfront protection structure; however, an oceanfront revetment is present fronting the adjoining property to the north.

### **2.10 Presence of pathways or stairs from the property to the beach**

The nearest public beach access occupies the western end of Mt. Angel Avenue, approximately 15 feet north of the site.

### **2.11 Existing human impacts on the site, particularly any that might alter the resistance to wave attack**

Human impacts are not contributing to the alteration of the resistance of the riprap revetment to wave attack west of the site.

## **3.0 Description of the Fronting Beach**

Neskowin Beach fronts the condominium property west of the site. Detailed descriptions of the characteristics of the beach are provided below.

### **3.1 Average widths of the beach during the summer and winter**

The beach near the site has a highly variable width, which is primarily dependent upon tide levels, and it tends to be narrower in the winter than in the summer. Although the beach can be more than 300 feet wide, at high tide, there is often no walkable beach. The beach here is very dynamic and changes morphology frequently, primarily due to rip current formation.

### **3.2 Median grain size of beach sediment**

During our site visit, we observed fine-grained to medium-grained beach sand.

### **3.3 Average beach slopes during the summer and winter**

Beach slopes vary from approximately 2 to 5 degrees depending upon recent accretion or erosion. The beaches tend to be flatter in the summer.

### **3.4 Elevations above mean sea level of the beach at the seaward edge of the property during summer and winter**

The property's western edge lies approximately 105 feet east of the upper edge of the riprap revetment west of the site. Lidar data from 2016 shows the junction between the beach and the revetment was at approximately 8 feet (NAVD 88). Allan and Hart (2005) surveyed the elevation of the beach/dune junction in 1997, 1998, and 2002 at approximately 23.9 feet, 19.2 feet, and 16 feet, respectively. Winter elevations primarily depend on beach profiles formed by storm conditions.

### **3.5 Presence of rip currents and rip embayments that can locally reduce the elevation of the fronting beach**

Rip currents and rip current embayments commonly contribute to erosion along the oceanfront in Neskowin. Narrow beaches and near-shore relatively deep water conditions contribute to rip current and rip current embayment formation.

It appears that rip currents have set-up in this general area consistently throughout the years, particularly north of Proposal Rock. As a result, future problems with rip current embayments and erosion should be expected in this area. When rip currents form, they create a channel of deeper water oriented perpendicular to the coastline. This commonly allows larger waves to travel further shoreward before breaking, adding to the erosive potential. When these channels terminate at the base of a riprap revetment, they have the potential to undermine the revetment, causing its failure. This appears to be partly responsible for the revetment failures seen in Neskowin. The potential for revetment failure by undermining is also increased at Neskowin because Neskowin is an old dune sheet, lacking rock at shallow depth on which to found the revetment.

### **3.6 Presence of rock outcrops and sea stacks, both offshore and within the beach zone**

Proposal Rock is located approximately 0.5 miles south of the site.

### **3.7 Information regarding the depth of beach sand down to bedrock at the seaward edge of the property**

Based on our experience with Neskowin sites in the vicinity, we estimate that bedrock lies more than 20 feet below beach level.

## **4.0 Geologic Hazards Analysis**

Our geologic hazards analysis is presented below.

#### **4.1 Subsurface Materials**

The site lies in an area that has been mapped as Pleistocene beach sand (Schlicker et al., 1972). Neskowin lies on a large dune complex which is approximately 4 miles long, north to south and extends from the coastline east to the base of the hills. This dune complex consists of numerous individual dunes which vary in age and stability. The area of the site has been mapped as a younger stabilized dune (open dune sand conditionally stable), which is a dune that has become conditionally stable regarding wind erosion (USDA et al., 1975). More recent mapping also identifies the area of the site as recently stabilized dunes (Allan, 2020). The dune consists of tan, loose, fine-grained sand with a thin, moderately developed topsoil. Under the Land Conservation and Development Commission (LCDC) classification system, the site is a Dune, Younger Stabilized.

Existing development, assumed buried utilities and installation, pavement, and hardscaping prevented subsurface investigation of the site with hand-augered equipment. Loose, unconsolidated dune sand was exposed on the ground surface around the site. Probing around the existing foundation indicated shallow spread footings.

#### **4.2 Geologic Structures**

Structural deformation and faulting along the Oregon Coast is dominated by the Cascadia Subduction Zone (CSZ) which is a convergent plate boundary extending for approximately 680 miles from northern Vancouver Island to northern California. This convergent plate boundary is defined by the subduction of the Juan de Fuca plate beneath the North America Plate and forms an offshore north-south trench approximately 60 miles west of the Oregon coast shoreline. A resulting deformation front consisting of north-south oriented reverse faults is present along the western edge of an accretionary wedge east of the trench, and a zone of margin-oblique folding and faulting extends from the trench to the Oregon Coast (Geomatrix, 1995).

A northwest-trending strike-slip fault is mapped near the site, extending from Proposal Rock to the southeast, approximately 4 miles (Snively et al., 1996). Based on mapping, the fault appears to offset middle Tertiary geologic units.

An unnamed offshore fault is mapped approximately 9 miles west of the site (Personius et al., 2003). The faults are part of a mapped group of left- and right-lateral strike-slip, normal, and reverse faults which offset accretionary wedge sediments underlying the continental shelf and slope in the forearc of the Cascadia Subduction Zone; some of the faults in this group also offset the overlying sedimentary section and underlying oceanic basalts of the subducting Juan de Fuca Plate (Personius et al., 2003). Most of the offshore faults in this group have strikes oblique to the Cascadia deformation front, suggesting a strong lateral component of slip. No detailed information on the ages of faulted deposits has been published, but similar offshore structures offset late Pleistocene

and Holocene sediments (Personius et al., 2003). An offshore thrust fault is also mapped approximately 2 miles west of the site (Personius et al., 2003).

The nearest potentially active fault is the Happy Camp Fault (formerly the Netarts Bay fault), which lies at the north end of Netarts Bay, approximately 23 miles north of the site (Geomatrix, 1995). This fault is a west-northwest trending, high angle reverse fault which cuts Miocene basaltic and Pleistocene channel deposits. This fault is believed to have been active approximately 125,000 years ago; however, it does not appear to cut 80,000-year-old marine terrace deposits, which suggests that the fault has not been active for at least 80,000 years (Geomatrix, 1995).

Other mapped potentially active faults are located in the Tillamook Bay fault zone approximately 31 miles north of the site, which are northwest-striking faults that offset the Eocene Tillamook Volcanics on the west flank of the Coast Range. No displacements in Quaternary deposits have been documented, but the fault zone parallels the mountain front that controls the northeastern margin of Tillamook Bay and thus has geomorphic expression consistent with Quaternary displacement (Personius et al., 2003).

#### **4.3 Slopes**

Slopes are discussed in detail in Section 2.2 above.

#### **4.4 Orientation of Bedding Planes in Relation to the Dip of the Surface Slope**

The site lies in an area mapped as dune sands which have beds of varying dip related to the surface slope. The underlying Basalt of Cascade Head has been mapped as dipping down to the north-northwest from 30 to 45 degrees (Snaveley et al., 1996). Grades at the subject site are primarily related to past grading and fill activities rather than the orientation of underlying units.

#### **4.5 Site Surface Water Drainage Patterns**

The ground surface surrounding the site gently slopes to the southeast. However, we anticipate most stormwater would easily infiltrate through the areas of exposed loose sand. At the time of our site visit, we observed no streams at the site. The nearest stream is Kiwanda Creek, located approximately 960 feet east of the site. Kiwanda Creek joins Neskowin Creek and discharges onto the beach approximately 0.5 miles south of the site.

#### **4.6 Dune Stability and Erosion**

The site is located on loose dune sand, which is easily eroded by ocean wave activity, and wind when devoid of vegetation. During the winters of 1998, 1999, 2000 and 2001, severe storms resulted in substantial ocean wave erosion, which removed active dunes in the area of the site. As reported by local residents, up to 10 feet of erosion has been observed during a single storm event. Ocean wave erosion has also resulted in lowering



of the beach elevation by several feet, allowing higher energy waves to impact the bluff. The increase in ocean wave erosion observed along much of the Oregon Coast in the recent past is a consequence of the mid-to-late 1990s El Niño/La Niña events, which altered ocean currents and transported much of the beach sand offshore. There has been some rebuilding of the beach in the last few years, but this has been a slow process. As a result, nearly all of Neskowin's oceanfront residences have had oceanfront protection installed.

The site lies along an area that has been hardened for hundreds of feet to the north and south. Most of this hardening has been constructed during and following the severe El Niño and La Niña events of the mid-to-late 1990s. All of the hardening in this area has been done with riprap revetments. Much of this riprap has needed repair of varying degree throughout the years. The southern part of The Breakers Condominiums, the two homes south of The Breakers Condominiums, and The Pacific Sands Condominiums to the south were particularly affected by early December 2007 and early January 2008 storms, and at least one of the homes required underpinning. These severe storms were accompanied by only moderately high tides. Had the storms been accompanied by higher tide levels, the damage could have been substantially worse. The riprap revetment greatly reduces the potential for erosion when maintained and repaired as necessary.

Mapping by Allan and Priest (2001) identifies the site within the High Hazard Zone. The dune slope and revetment areas west of the site are mapped in the active coastal erosion hazard zones. The active coastal erosion hazard zone is defined as an area that is being actively eroded by ocean waves and the mass movements directly caused by wave action, and the high coastal erosion hazard zone is defined as an area having a high probability that it could be affected by active erosion in the next ~ 60 to 100 years (Allan and Priest, 2001). It should be noted that the mapping done for the 2001 study was intended for regional planning use, not for site-specific hazard identification.

#### **4.7 Regional Seismic Hazards**

Abundant evidence indicates that a series of geologically recent large earthquakes related to the Cascadia Subduction Zone have occurred along the coastline of the Pacific Northwest. Evidence suggests that more than 40 great earthquakes of magnitude 8 and larger have struck western Oregon during the last 10,000 years. The calculated odds that a Cascadia earthquake will occur in the next 50 years range from 7–15 percent for a great earthquake affecting the entire Pacific Northwest, to about a 37 percent chance that the southern end of the Cascadia Subduction Zone will produce a major earthquake in the next 50 years (OSSPAC, 2013; OSU News and Research Communications, 2010; Goldfinger et al., 2012). Evidence suggests the last major earthquake occurred on January 26, 1700, and may have been of magnitude 8.9 to 9.0 (Clague et al., 2000).

There is now increasing recognition that great earthquakes do not necessarily result in a complete rupture along the full 1,200 km fault length of the Cascadia subduction zone. Evidence in the paleorecords indicates that partial ruptures of the plate boundary have occurred due to smaller earthquakes with moment magnitudes ( $M_w$ ) < 9 (Witter et al., 2003; Kelsey et al., 2005). These partial segment ruptures appear to occur more frequently on the southern Oregon coast, as determined from paleotsunami studies. Furthermore, the records have documented that local tsunamis from Cascadia earthquakes recur in clusters (~250–400 years) followed by gaps of 700–1,300 years, with the higher tsunamis associated with earthquakes occurring at the beginning and end of a cluster (Allan et al., 2015).

These major earthquake events were accompanied by widespread subsidence of a few centimeters to 1–2 meters (Leonard et al., 2004). Tsunamis appear to have been associated with many of these earthquakes. In addition, settlement, liquefaction, and landsliding of some earth materials are believed to have been commonly associated with these seismic events.

Other earthquakes related to shallow crustal movements or earthquakes related to the Juan de Fuca plate have the potential to generate magnitude 6.0 to 7.5 earthquakes. The recurrence interval for these types of earthquakes is difficult to determine from present data, but estimates of 100 to 200 years have been given in the literature (Rogers et al., 1996).

The expected strength of shaking to occur at the site during an earthquake in a 500-year period has been mapped as severe (DOGAMI Oregon HazVu website, accessed May 2023). “Severe” is the second-highest level of a six-level gradation from “Light” to “Violent” in this mapping system.

#### Liquefaction and Settlement

DOGAMI’s HazVu website (<https://gis.dogami.oregon.gov/maps/hazvu/>) has mapped the area of the site as having a high susceptibility to liquefaction. DOGAMI states: “Buildings and infrastructure sitting on these soils are likely to be severely damaged in an earthquake.”

Liquefaction occurs when saturated, cohesionless soils are subjected to ground vibrations, resulting in a decrease in the volume of the soil. If drainage is unable to occur, the tendency to decrease in volume results in an increase in pore water pressure. If the pore water pressure builds up to the point at which it is equal to the overburden pressure, the effective stress becomes zero, and the soil loses its strength and develops a liquefied state. Liquefaction is most common in saturated, loose, granular soils, sand or silty sand materials. Cohesive soils, such as clayey silt and clay, will generally not liquefy during

earthquakes. Older sediments are also more resistant to liquefaction than recently deposited sediments (Idris and Boulanger, 2008).

Settlement can be the result of liquefaction of saturated soils or simply a result of dry soil densifying under vibration (volumetric compression). Volumetric compression during an earthquake is the result of vibrations of the soil, which cause soil particles to settle into a denser state, decreasing the volume of the soil. The degree of settlement is primarily dependent upon the initial density of the soil and the magnitude and duration of ground vibration (shaking). Settlement caused by liquefaction is commonly differential, and the magnitude of settlement typically varies throughout a site, whereas settlement caused by volumetric compression tends to be more uniform.

#### **4.8 Flooding Hazards**

Based on the 2018 Flood Insurance Rate Map (FIRM, Panel #41057C1005F), the area of the site lies in an area rated as Zone VE (EL 32), defined as a special flood hazard area with base flood elevations determined, and subject to inundation by the 1-percent-annual-chance flood event with additional hazards due to storm-induced velocity wave action.

The beach and revetment area west of the site lies in an area rated as Zone VE (EL 41.3 feet) (NAVD 88), which is defined as a special flood hazard area with base flood elevations determined, and subject to inundation by the 1-percent-annual-chance flood event with additional hazards due to storm-induced velocity wave action. The area east of the revetment and west of the site lies in an area rated as Zone VE (EL 33), defined as a special flood hazard area with base flood elevations determined and subject to inundation by the 1-percent-annual-chance flood event with additional hazards due to storm-induced velocity wave action; the area east of the site is mapped as an area rated as Zone AE (EL 25) which is defined as an area of 1-percent-annual-chance of being flooded and wave heights are less than 3 feet.

Based on the Oregon Department of Geology and Mineral Industries mapping (DOGAMI, 2012), the subject site lies within the tsunami inundation zone resulting from an approximately 8.7 and greater magnitude Cascadia Subduction Zone (CSZ) earthquake. The 2012 DOGAMI mapping is based upon 5 computer-modeled scenarios for shoreline tsunami inundation caused by potential CSZ earthquake events ranging in magnitude from approximately 8.7 to 9.1. The January 1700 earthquake event (discussed in Section 4.7 above) has been rated as an approximate 8.9 magnitude in DOGAMI's methodology. More distant earthquake source zones can also generate tsunamis.

#### **4.9 Climate Change**

According to most of the recent scientific studies, the Earth's climate is changing as the result of human activities which are altering the chemical composition of the atmosphere through the buildup of greenhouse gases, primarily carbon dioxide, methane, nitrous

oxide, and chlorofluorocarbons (EPA, 1998). Although there are uncertainties about exactly how and when the Earth's climate will respond to enhanced concentrations of greenhouse gases, scientific observations indicate that detectable changes are underway (EPA, 1998; Church and White, 2006). Global sea level rise, caused by melting polar ice caps and ocean thermal expansion, could lead to flooding of low-lying coastal property, loss of coastal wetlands, erosion of beaches and bluffs, and saltwater contamination of drinking water. Global climate change and the resultant sea level rise will likely impact the subject site through accelerated coastal erosion and more frequent and severe flooding.

#### **4.10 Analyses of Erosion and Flooding Potential**

##### 4.10.1 Analysis of DOGAMI beach monitoring data available for the site (if available).

DOGAMI beach monitoring data has been collected for Neskowin Beach, approximately 1,300 feet south of the site, regularly since 1997. Following the winter storms of 2006-2008 and the construction of the revetments along the beach south of the site, beach elevations there have varied by several feet from minimum to maximum over the monitored period of 1999 to 2023 (Allan and Hart, 2005; Allan and Hart, 2007; Allan and Hart, 2008; Allan et al., 2015; NANOOS, accessed May 2023).

##### 4.10.2 Analysis of human activities affecting shoreline erosion.

Armoring of the shoreline with riprap has reduced erosion along the beach.

##### 4.10.3 Analysis of possible mass wasting, including weathering processes, landsliding, or slumping.

The erosive processes affecting the site are discussed in detail in Section 4.6 (above).

##### 4.10.4 Calculation of wave run-up beyond mean water elevation that might result in erosion of the sea cliff or foredune.

Coastal erosion rates and hazard zones (as referenced in Allan and Priest, 2001) were presented in Section 4.6 Dune Stability and Erosion (above). In the dune-backed shoreline recession methodology applicable to the subject site, the total water level produced by the combined effect of wave runup plus the tidal elevation must exceed some critical elevation of the fronting beach, typically the elevation of the beach-dune junction. Wave runup elevation can change with many variables, such as changing beach elevations, the presence of transient dunes, etc. The dune is

protected by the riprap revetment west of the subject site, and this shoreline recession methodology is not appropriate for the site.

4.10.5 Evaluation of frequency that erosion-inducing processes could occur, considering the most extreme potential conditions of unusually high water levels together with severe storm wave energy.

On this stretch of dune-backed shoreline, erosion-inducing processes are daily in the form of constant wave attack at the base of the revetment at high tide. High water levels, flooding, and severe storms can cause rip currents, which have the potential to undermine the revetment west of the site.

4.10.6 For dune-backed shoreline, use an established geometric model to assess the potential distance of property erosion, and compare the results with direct evidence obtained during site visits, aerial photo analysis, or analysis of DOGAMI beach monitoring data.

Not applicable to the subject site or nearby area, which is a dune-backed shoreline that has been extensively riprapped; see Section 4.10.4 (above).

4.10.7 For bluff-backed shorelines, use a combination of published reports, such as DOGAMI bluff and dune hazard risk zone studies, aerial photo analysis, and fieldwork, to assess the potential distance of property erosion.

Not applicable to the subject site, which lies in a dune-backed shoreline area.

4.10.8 Description of potential for sea level rise, estimated for local area by combining local tectonic subsidence or uplift with global rates of predicted sea level rise.

Based on data from NOAA monitoring stations at South Beach and Garibaldi, this general area of Oregon's coastline has a mean sea level rise of approximately 2.08 mm/year, which includes the combined effects of global rates of sea level rise and landmass elevation changes (NOAA Tides & Currents Sea Level Trends <http://tidesandcurrents.noaa.gov/sltrends/sltrends.html>). Additional observations are addressed in Section 4.9 of this report.

#### **4.11 Assessment of Potential Reactions to Erosion Episodes**

4.11.1 Determination of legal restrictions of shoreline protective structures (Goal 18 prohibition, local conditional use requirements, priority for non-structural erosion control methods).

As previously noted, riprap revetments are present west of the subject site and for hundreds of feet to the north and south in this oceanfront area of Neskowin. Lots in the area of the site were generally 'developed' on January 1, 1977; however, this is a legal issue that can have varying interpretations. Most lots in this area, including the subject site, generally meet Oregon's Goal 18 exception requirements to obtain protection when a structure is threatened by erosion.

According to the Ocean Shores Viewer (<http://www.coastalatlantlas.net/oceanshores/>, accessed May 2023), the oceanfront condominium property that the site occupies, the area around the subject site, appears eligible due to exception under the GOAL 18 Eligibility Inventory with a mapped beachfront protective structure.

4.11.2 Assessment of potential reactions to erosion events, addressing the need for future erosion control measures, building relocation, or building foundation and utility repairs.

Residential development recommendations, including erosion control and foundation design recommendations, will be provided in the geotechnical investigation recommended and discussed below.

#### **5.0 Conclusions and Preliminary Recommendations for Further Work**

The main engineering geologic concerns at the site are:

1. The site lies on dune sands that are poorly consolidated and subject to settlement and liquefaction, as well as ongoing coastal erosion if the revetment is damaged. Inherent risks of seismic hazards, flooding, coastal erosion, and future sand movement, including accretion at this site, must be accepted by the owner, future owners, developers, and residents.
2. The subject site and surrounding properties are mapped within a FEMA special flood hazard area and are subject to coastal flooding.
3. Based on our site observations, the existing fire-damaged building at the site appears to be supported on conventional shallow foundations. Based on the mapped hazards

at the site, this foundation does not appear suitable for reuse with the proposed development.

4. There is an inherent regional risk of earthquakes along the Oregon Coast, which could cause harm and damage structures. Ground shaking during an earthquake can cause soil consolidation resulting in settlement of the structures and can cause soils to liquefy, resulting in the loss of bearing capacity and structural damage. The site also lies in a mapped tsunami hazard zone. A tsunami impacting the Neskowin area could cause harm, loss of life, and damage to structures. Hazards associated with tsunami flooding resulting from a large seismic event cannot be economically mitigated for. These risks must be accepted by the owner, future owners, developers, and residents of the site.

#### Recommendations for further work

All future development recommendations for the site assume the revetment west of the site will be maintained and repaired as necessary.

New construction or a substantial improvement of a residential building at the site is feasible, pending the results of the recommended geotechnical investigation discussed below. Based on the geologic hazards related to the development of the site, we have provided the following preliminary design considerations with respect to new construction or a substantial improvement:

Based on FEMA FIRM mapping, new or substantially improved buildings should be supported on a deep foundation system. Foundations will need to support vertical loads and provide support in the event of wave overtopping or ocean undercutting of the dune encroaching to the proposed foundation area. Foundations will also need to resist uplift forces. An open foundation or breakaway wall design may be necessary for the area below the lowest floor. V Zone standards will apply to the site, and we recommend that you design to these standards. Foundations in V Zones are required to be on piers or piling capable of resisting simultaneous wind and flood loads (with wave action).

Typically, the lowest horizontal structural members of the new building should be a minimum of 1 foot or more above base flood elevations. Additional freeboard may be necessary. We recommend that a benchmark be set prior to construction and that a certificate of elevation be obtained for the completed construction. In addition, a V Zone Design Certificate is recommended.

HGSA will need to complete a geotechnical investigation to provide recommendations for this type of site development and deep foundations. Locating services of private and public buried utilities and installations in the area of the site will be necessary.

Equipment access and associated logistics will need to be determined before the geotechnical site investigation can commence. Preparation of the site may be necessary prior to completing the geotechnical investigation. This investigation will likely include subsurface exploration with geotechnical drilling, laboratory testing, and geotechnical analysis. Following the geotechnical investigation, HGSA will likely need to consult with the designer, structural engineer, general contractor, and foundation contractor.

## **6.0 Limitations**

The Oregon Coast is a dynamic environment with inherent unavoidable risks to development. Landsliding, erosion, tsunamis, storms, earthquakes and other natural events can cause severe impacts to structures built within this environment and can be detrimental to the health and welfare of those who choose to place themselves within this environment. The client is warned that, although this report is intended to identify the geologic hazards causing these risks, the scientific and engineering communities' knowledge and understanding of geologic hazards processes is not complete.

Our investigation was based on engineering geological reconnaissance, limited review of published information, and our subsurface exploration and analyses. The data presented in this report are believed to be representative of the site. The conclusions herein are professional opinions derived in accordance with current standards of professional practice and budget constraints. No warranty is expressed or implied. The performance of the site during a seismic event has not been evaluated. If you would like us to do so, please contact us.

The soil and related information depict generalized subsurface conditions only at these specific locations and at the particular time the subsurface exploration was completed. Soil, rock, and groundwater conditions at other locations may differ from the conditions at these boring locations. Also, the passage of time may result in a change in the soil and groundwater conditions at the site.

This report pertains to the subject site only, and is not applicable to adjacent sites nor is it valid for types of development other than that to which it refers. Geologic conditions including materials, processes, and rates can change with time and therefore, a review of the site and/or this report may be necessary as time passes to assure its accuracy and adequacy. This report may only be copied in its entirety.

## **7.0 Disclosure**

H.G. Schlicker & Associates, Inc. and the undersigned Certified Engineering Geologist have no financial interest in the subject site, the project or the Client's organization.



## **8.0 References Cited**

- Allan, J. C. and Hart, R., 2005, A geographical information system (GIS) data set of beach morphodynamics derived from 1997, 1998, and 2002 LIDAR data for the central to northern Oregon coast: Technical Report to the Oregon Department of Land Conservation and Development: Oregon Department of Geology and Mineral Industries, Open-File Report O-05-09, 16 pages.
- Allan, J. C. and Hart, R., 2007, Assessing the temporal and spatial variability of coastal change in the Neskowin littoral cell: developing a comprehensive monitoring program for Oregon beaches: Technical Report to the Oregon Department of Land Conservation and Development: Oregon Department of Geology and Mineral Industries, Open-File Report O-07-01, 27 pages.
- Allan, J.C., and Hart, R., 2008, Oregon beach and shoreline mapping and analysis program: 2007-2008 beach monitoring report: Oregon Department of Geology and Mineral Industries Open file report O-08-15, 60 p.
- Allan, J.C., Ruggiero, P., Garcia, G., O'Brien, F. E., Stimely, L. L., and Roberts, J. T., 2015, Coastal Flood Hazard Study, Tillamook County, Oregon: Oregon Department of Geology and Mineral Industries Special Paper 47, 274 p.
- Allan, J. C. and Priest, G. R., 2001, Evaluation of coastal erosion hazard zones along dune and bluff backed shorelines in Tillamook County, Oregon: Cascade Head to Cape Falcon: Oregon Department of Geology and Mineral Industries, Open-File Report O-01-03, 126p., maps.
- Allan, J. C., 2020, Temporal and Spatial Changes in Coastal Morphology, Tillamook County, Oregon: Oregon Department of Geology and Mineral Industries, Open-File Report O-20-04, 27 p. report, geodatabase, metadata
- Calhoun, N. C., Burns, W. J., and Franczyk, J. J., 2020, Landslide hazard and risk study of Tillamook County, Oregon: Oregon Department of Geology and Mineral Industries, Open-File Report O-20-13, scale 1:8,000.
- Church, J. A., and White, N. J., 2006, A 20<sup>th</sup> century acceleration in global sea-level rise; Geophysical Research Letters, v. 22, LO1601, 4 p.
- Clague, J. J., Atwater, B. F., Wang, K., Wang, Y., and Wong, I., 2000, Penrose Conference 2000 - Great Cascadia Earthquake Tricentennial, Programs Summary and Abstracts: Oregon Department of Geology and Mineral Industries, Special Paper 33, 156 p.

- DOGAMI, 2012, Tsunami inundation maps for Neskowin, Tillamook County, Oregon: Oregon Department of Geology and Mineral Industries, TIM-Till-14, maps.
- EPA, 1998, Climate Change and Oregon: Environmental Protection Agency, EPA 236-98-007u, 4 p.
- Geomatrix Consultants, 1995, Seismic design mapping, State of Oregon, final report: Prepared for the Oregon Department of Transportation, Project No. 2442.
- Goldfinger, C., Nelson, C. H., Morey, A. E., Johnson, J. E., Patton, J. R., Karabanov, E., Gutiérrez-Pastor, J., Eriksson, A. T., Gràcia, E., Dunhill, G., Enkin, R. J., Dallimore, A., and Vallier, T., 2012, Turbidite event history—Methods and implications for Holocene paleoseismicity of the Cascadia subduction zone: U.S. Geological Survey Professional Paper 1661–F, 170 p.
- Idris, I. M., and Boulanger, R. W., 2008, Soil Liquefaction During Earthquakes: Earthquake Engineering Research Institute, 243 p.
- Kelsey, H. M., Nelson, A. R., Hemphill-Haley, E., and Witter, R. C., 2005, Tsunami history of an Oregon coastal lake reveals a 4600 yr record of great earthquakes on the Cascadia subduction zone: Geological Society of America Bulletin, v. 117, no. 7/8, p. 1009-1032.
- Leonard, L. J., Hyndman, R. D., and Mazzotti, S., 2004, Coseismic subsidence in the 1700 great Cascadia earthquake: Coastal estimates versus elastic dislocation models: Geological Society of America Bulletin, May/June 2004, v. 116, no. 5/6, pp. 655–670.
- NANOOS, Beach Monitoring Data, <http://nvs.nanoos.org/BeachMapping>, Oct 1997 to Mar 2023.
- Oregon Seismic Safety Policy Advisory Commission (OSSPAC), February 2013, The Oregon Resilience Plan: Reducing Risk and Improving Recovery for the next Cascadia Earthquake and Tsunami—Report to the 77<sup>th</sup> Legislative Assembly: State of Oregon Office of Emergency Management, 341 p.
- OSU News and Research Communications, May 24, 2010, Odds are 1-in-3 that a huge quake will hit Northwest in next 50 years: Oregon State University, Corvallis <http://oregonstate.edu/ua/ncs/archives/2010/may/odds-huge-quake-Northwest-next-50-years>
- Personius, S. F., Dart, R. L., Bradley, L-A, Haller, K. M., 2003, Map and data for Quaternary faults and folds in Oregon: U.S. Geological Survey, Open-File Report 03-095, 556 p., map.
- Rogers, A. M., Walsh, T. J., Kockelman, J., and Priest, G. R., 1996, Earthquake hazards in the Pacific Northwest - an overview: U.S. Geological Survey, Professional Paper 1560, p. 1- 54.

Schlicker, H. G., Deacon, R. J., Beaulieu, J. D., and Olcott, G. W., 1972, Environmental geology of the coastal region of Tillamook and Clatsop Counties, Oregon: Oregon Department of Geology and Mineral Industries, Bulletin 74, 164 p., maps.

Snively, P. D., Niem, A., Wang, F. L., MacLeod, N. S., and Calhoun, T. K., 1996, Geologic map of the Cascade Head Area, Northwestern Oregon Coast Range (Neskowin, Nestucca Bay, Hebo, and Dolph 7.5 minute Quadrangles): U.S. Geological Survey, Open-File Report 96-0534, 16 p., maps.

USDA Soil Conservation Service, and Oregon Coastal Conservation and Development Commission, 1975, Beaches and dunes of the Oregon Coast: 161 p.

Witter, R. C., Kelsey, H. M., and Hemphill-Haley, E., 2003, Great Cascadia earthquakes and tsunamis of the past 6700 years, Coquille River estuary, southern coastal Oregon: Geological Society of America Bulletin, v. 115, p. 1289-1306.

It has been our pleasure to serve you. If you have any questions concerning this report, or the site, please contact us.

Respectfully submitted,

**H.G. SCHLICKER AND ASSOCIATES, INC.**

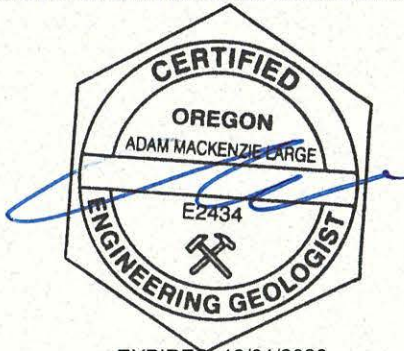

EXPIRES: 12/31/2023

Adam M. Large, MSc, RG, CEG  
President/Principal Engineering Geologist

AML:mgb

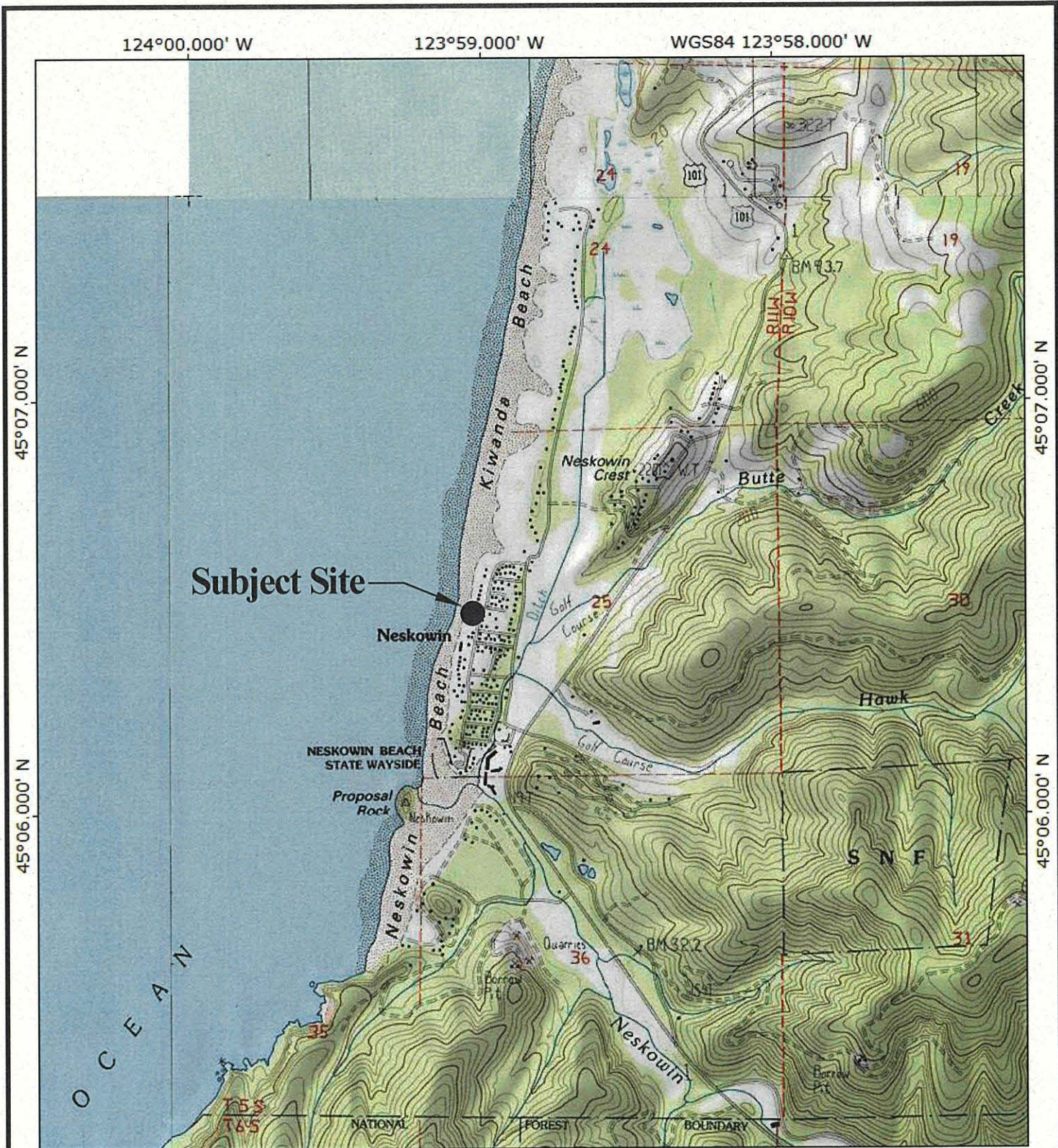

Date: 05/23/2023	<b>Project #Y234676</b>	Prepared by: MGB
Scale: 1" = 2,000'		Approved by: AML
<b>Location Map</b> Tax Lot 92411, Map 5S-11W-25CB Supp. Map No. 2 Lot-Unit 11, 48060 Breakers Blvd, Neskowin, Tillamook County, Oregon		
 <b>H.G. Schlicker &amp; Associates, Inc.</b>		<b>Figure 1</b>

2 WAS PREPARED FOR  
MENT PURPOSE ONLY

SUPPLEMENTAL MAP NO. 2  
NW1/4 SW1/4 SEC. 25 T.5S R.11W. W.M.

1" = 20'

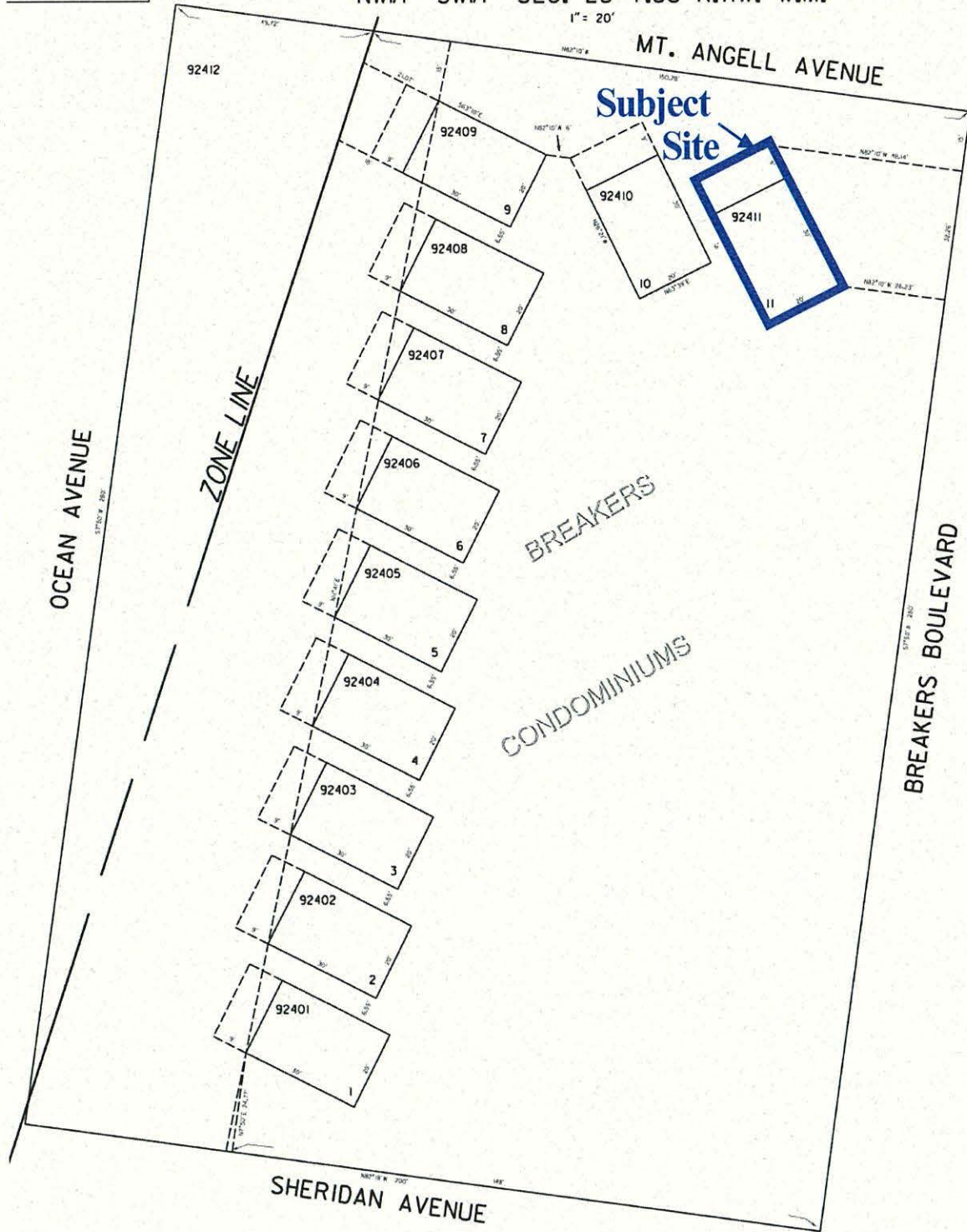

Date: 05/23/2023

Scale: 1" = 40'

**Project #Y234676**

Prepared by: MGB

Approved by: AML

**Plat Map**

Tax Lot 92411, Map 5S-11W-25CB Supp. Map No. 2  
Lot-Unit 11, 48060 Breakers Blvd, Neskowin, Tillamook County, Oregon

Modified from the Tillamook County assessor's plat  
5S-11W-25CB Supp. No. 2  
All locations and dimensions are approximate.

 **H.G. Schlicker & Associates, Inc.**

**Figure 2**

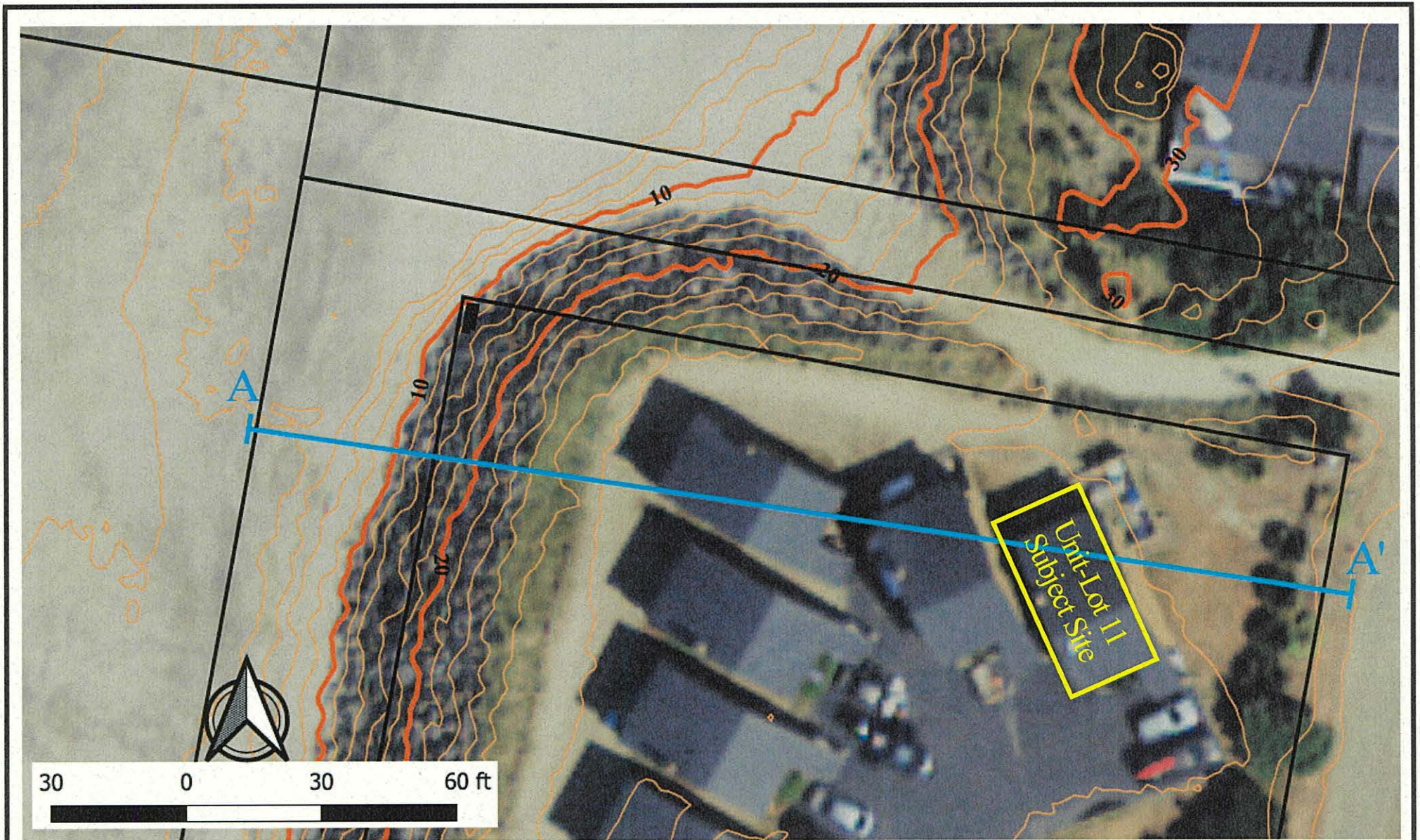

Imagery provided by 2018 Oregon Explorer  
 Topographic data derived from West Coast 2016\_El\_Nino Lidar data from NOAA  
 All locations and dimensions are approximate.

A — A' = Approximate trend of profile line

Date: 05/23/2023	<b>Project #Y234676</b>	Prepared by: MGB	<b>Site Topographic Map</b>	 <b>H.G. Schlicker &amp; Associates, Inc.</b>	<b>Figure 3</b>
Scale: 1" = 30'		Approved by: AML	Tax Lot 92411, Map 5S-11W-25CB Supp. No. 2; Lot-Unit 11 48060 Breakers Blvd, Neskowin, Tillamook County, Oregon		

A

North 83° West  
←————→

A'

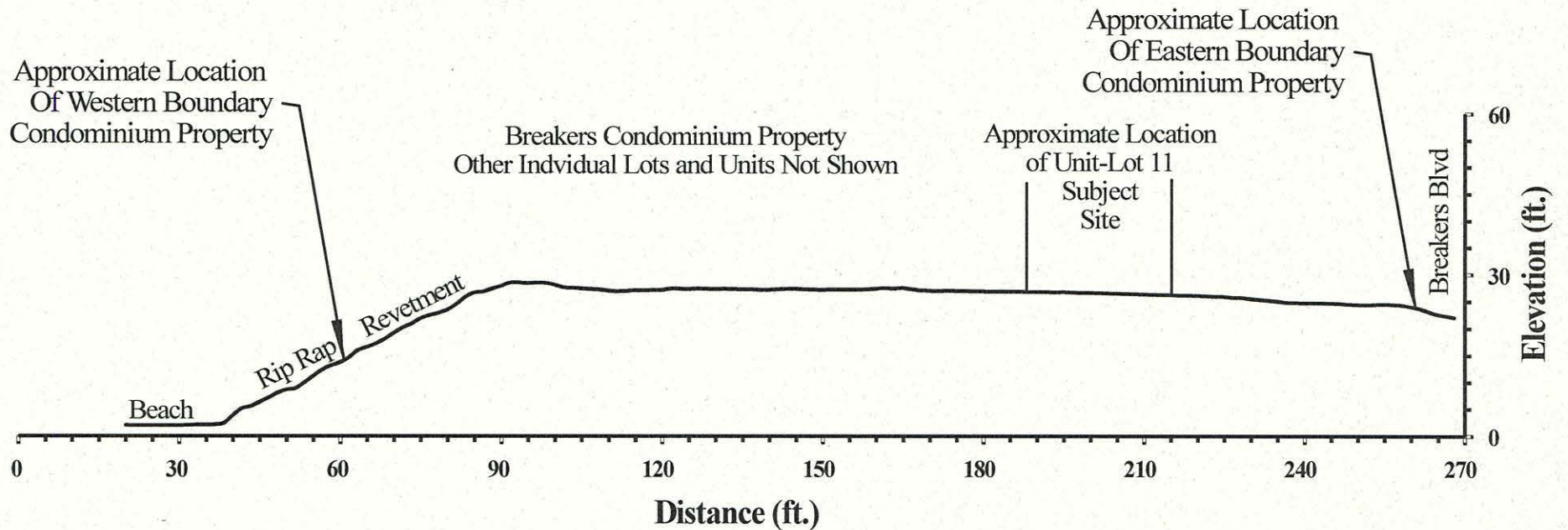

Date: 05/23/2023	<b>Project #Y234676</b>	Prepared by: MGB
Scale: 1" = 30'		Approved by: AML
<b>Slope Profile, A-A'</b> Tax Lot 92411, Map 5S-11W-25CB Supp. No. 2 Lot-Unit 11, 48060 Breakers Blvd., Neskowin, Tillamook County, Oregon		
 <b>H.G. Schlicker &amp; Associates, Inc.</b>		<b>Figure 4</b>

All dimensions, elevations and locations are approximate.  
 Slope profile derived from West\_Coast\_2016\_El\_Nino Lidar data from NOAA.

Project #Y234676

Appendix A  
- Site Photographs -





Photo 1 – Northeasterly view of the subject site from the parking lot of Breakers Condominium.



Photo 2 – Southeasterly view of the subject site occupied by the existing fire-damaged residential building.



Photo 3 – Southwesterly view of the subject site from near the intersection of Breakers Blvd and Mt. Angel Ave.



Photo 4 – Easterly view of the site from the beach access ramp at the western end of Mt. Angel Ave.



Photo 5 – Easterly view of the oceanfront area west of the site from the beach.



Photo 6 – Southerly view of the beach and rip rap revetment west of the site.



Photo 7 – Westerly view from the top of the revetment, west of the site.



Photo 8 – Close-up view of a manhole near the site indicating the potential presence of buried private utilities and installations.

NOTES:  
1. ALL DIMENSIONS ARE TO FACE UNLESS NOTED OTHERWISE.  
2. FINISHES TO BE DETERMINED BY THE ARCHITECT.  
3. SEE SPECIFICATIONS FOR MATERIALS AND METHODS OF CONSTRUCTION.  
4. ALL WORK SHALL BE IN ACCORDANCE WITH THE 2018 INTERNATIONAL RESIDENTIAL CODE AND ALL APPLICABLE LOCAL ORDINANCES.  
5. THE ARCHITECT SHALL BE RESPONSIBLE FOR OBTAINING ALL NECESSARY PERMITS AND APPROVALS FROM THE APPLICABLE AGENCIES.  
6. THE ARCHITECT SHALL BE RESPONSIBLE FOR VERIFYING THE ACCURACY OF ALL DIMENSIONS AND CONDITIONS OF THE SITE.  
7. THE ARCHITECT SHALL BE RESPONSIBLE FOR COORDINATING ALL TRADES AND SUBCONTRACTORS.  
8. THE ARCHITECT SHALL BE RESPONSIBLE FOR PROVIDING ALL NECESSARY DETAILS AND SECTION CUTS.  
9. THE ARCHITECT SHALL BE RESPONSIBLE FOR OBTAINING ALL NECESSARY CONTRACTS AND AGREEMENTS FROM THE SUBCONTRACTORS.  
10. THE ARCHITECT SHALL BE RESPONSIBLE FOR MONITORING THE CONSTRUCTION AND REPORTING ANY DISCREPANCIES TO THE OWNER.  
11. THE ARCHITECT SHALL BE RESPONSIBLE FOR PROVIDING ALL NECESSARY AS-BUILT DRAWINGS.  
12. THE ARCHITECT SHALL BE RESPONSIBLE FOR OBTAINING ALL NECESSARY RECORDS AND DOCUMENTATION.  
13. THE ARCHITECT SHALL BE RESPONSIBLE FOR PROVIDING ALL NECESSARY SUPPORTING DOCUMENTATION.  
14. THE ARCHITECT SHALL BE RESPONSIBLE FOR OBTAINING ALL NECESSARY REFERENCES.  
15. THE ARCHITECT SHALL BE RESPONSIBLE FOR OBTAINING ALL NECESSARY CONTACT INFORMATION.  
16. THE ARCHITECT SHALL BE RESPONSIBLE FOR OBTAINING ALL NECESSARY COMMUNICATIONS.  
17. THE ARCHITECT SHALL BE RESPONSIBLE FOR OBTAINING ALL NECESSARY RECORDS.  
18. THE ARCHITECT SHALL BE RESPONSIBLE FOR OBTAINING ALL NECESSARY DOCUMENTATION.  
19. THE ARCHITECT SHALL BE RESPONSIBLE FOR OBTAINING ALL NECESSARY SUPPORTING DOCUMENTATION.  
20. THE ARCHITECT SHALL BE RESPONSIBLE FOR OBTAINING ALL NECESSARY REFERENCES.  
21. THE ARCHITECT SHALL BE RESPONSIBLE FOR OBTAINING ALL NECESSARY CONTACT INFORMATION.  
22. THE ARCHITECT SHALL BE RESPONSIBLE FOR OBTAINING ALL NECESSARY COMMUNICATIONS.  
23. THE ARCHITECT SHALL BE RESPONSIBLE FOR OBTAINING ALL NECESSARY RECORDS.  
24. THE ARCHITECT SHALL BE RESPONSIBLE FOR OBTAINING ALL NECESSARY DOCUMENTATION.  
25. THE ARCHITECT SHALL BE RESPONSIBLE FOR OBTAINING ALL NECESSARY SUPPORTING DOCUMENTATION.  
26. THE ARCHITECT SHALL BE RESPONSIBLE FOR OBTAINING ALL NECESSARY REFERENCES.  
27. THE ARCHITECT SHALL BE RESPONSIBLE FOR OBTAINING ALL NECESSARY CONTACT INFORMATION.  
28. THE ARCHITECT SHALL BE RESPONSIBLE FOR OBTAINING ALL NECESSARY COMMUNICATIONS.  
29. THE ARCHITECT SHALL BE RESPONSIBLE FOR OBTAINING ALL NECESSARY RECORDS.  
30. THE ARCHITECT SHALL BE RESPONSIBLE FOR OBTAINING ALL NECESSARY DOCUMENTATION.  
31. THE ARCHITECT SHALL BE RESPONSIBLE FOR OBTAINING ALL NECESSARY SUPPORTING DOCUMENTATION.  
32. THE ARCHITECT SHALL BE RESPONSIBLE FOR OBTAINING ALL NECESSARY REFERENCES.  
33. THE ARCHITECT SHALL BE RESPONSIBLE FOR OBTAINING ALL NECESSARY CONTACT INFORMATION.  
34. THE ARCHITECT SHALL BE RESPONSIBLE FOR OBTAINING ALL NECESSARY COMMUNICATIONS.  
35. THE ARCHITECT SHALL BE RESPONSIBLE FOR OBTAINING ALL NECESSARY RECORDS.  
36. THE ARCHITECT SHALL BE RESPONSIBLE FOR OBTAINING ALL NECESSARY DOCUMENTATION.  
37. THE ARCHITECT SHALL BE RESPONSIBLE FOR OBTAINING ALL NECESSARY SUPPORTING DOCUMENTATION.  
38. THE ARCHITECT SHALL BE RESPONSIBLE FOR OBTAINING ALL NECESSARY REFERENCES.  
39. THE ARCHITECT SHALL BE RESPONSIBLE FOR OBTAINING ALL NECESSARY CONTACT INFORMATION.  
40. THE ARCHITECT SHALL BE RESPONSIBLE FOR OBTAINING ALL NECESSARY COMMUNICATIONS.  
41. THE ARCHITECT SHALL BE RESPONSIBLE FOR OBTAINING ALL NECESSARY RECORDS.  
42. THE ARCHITECT SHALL BE RESPONSIBLE FOR OBTAINING ALL NECESSARY DOCUMENTATION.  
43. THE ARCHITECT SHALL BE RESPONSIBLE FOR OBTAINING ALL NECESSARY SUPPORTING DOCUMENTATION.  
44. THE ARCHITECT SHALL BE RESPONSIBLE FOR OBTAINING ALL NECESSARY REFERENCES.  
45. THE ARCHITECT SHALL BE RESPONSIBLE FOR OBTAINING ALL NECESSARY CONTACT INFORMATION.  
46. THE ARCHITECT SHALL BE RESPONSIBLE FOR OBTAINING ALL NECESSARY COMMUNICATIONS.  
47. THE ARCHITECT SHALL BE RESPONSIBLE FOR OBTAINING ALL NECESSARY RECORDS.  
48. THE ARCHITECT SHALL BE RESPONSIBLE FOR OBTAINING ALL NECESSARY DOCUMENTATION.  
49. THE ARCHITECT SHALL BE RESPONSIBLE FOR OBTAINING ALL NECESSARY SUPPORTING DOCUMENTATION.  
50. THE ARCHITECT SHALL BE RESPONSIBLE FOR OBTAINING ALL NECESSARY REFERENCES.

Evgeni Shegrev  
P.O. Box 156 Gervais, OR 97026  
P: (503) 504-8318  
evgeni@toplinedn.com

Meredith Lodging  
48060 Breakers Blvd.  
Neskowin, OR 97149

DATE: 12/7/2023  
SCALE: 1/4" = 1'-0"  
DRAWN: BS  
JOB: 23-104  
SHEET: C

FOR CITY OFFICIAL USE

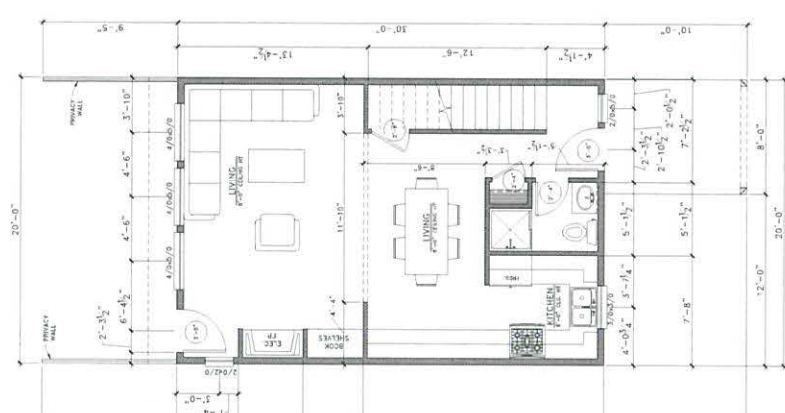
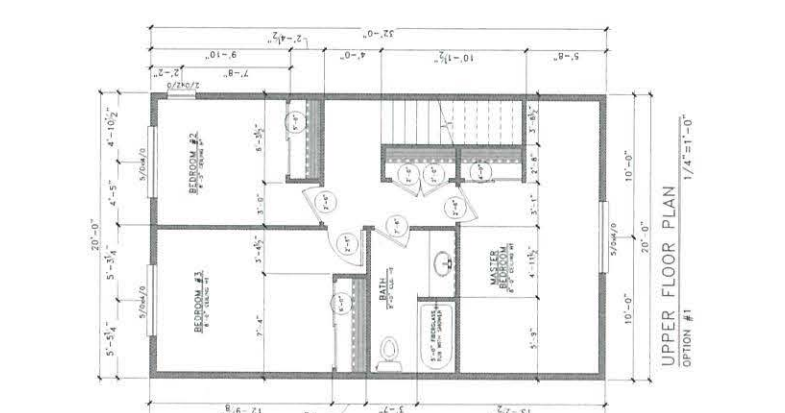
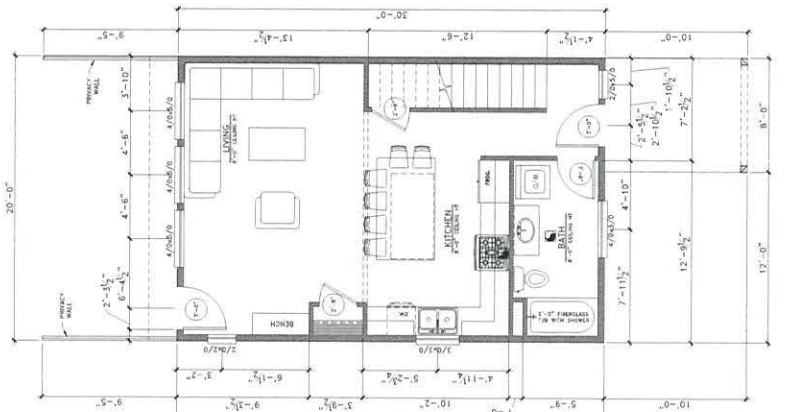
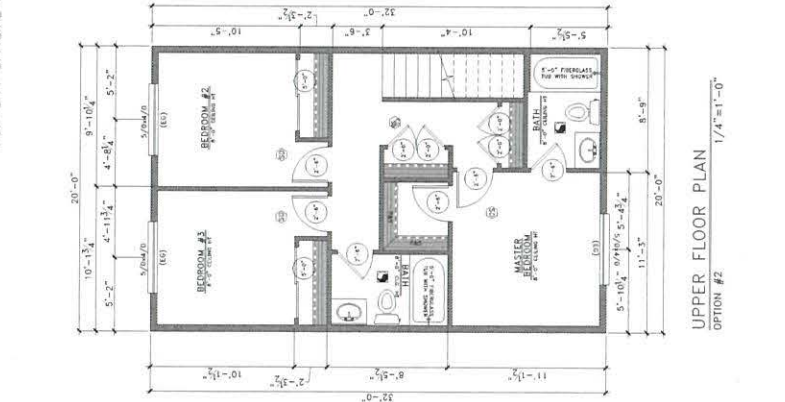



FRONT ELEVATION

1/4"=1'-0"

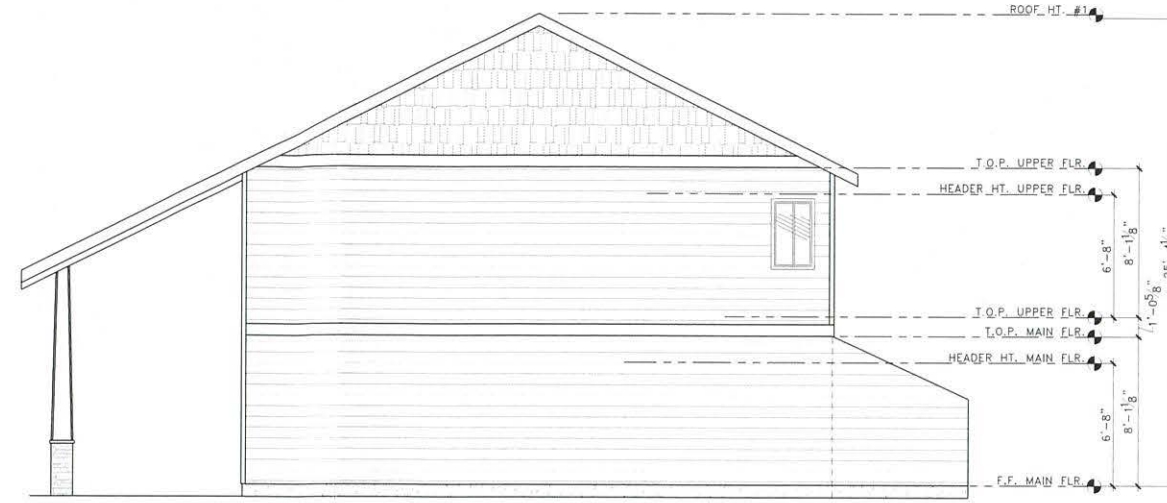

RIGHT SIDE ELEVATION

1/4"=1'-0"

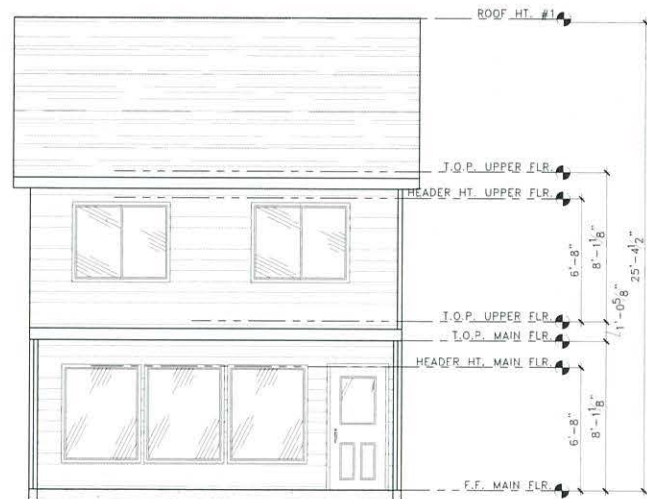

REAR ELEVATION

1/4"=1'-0"

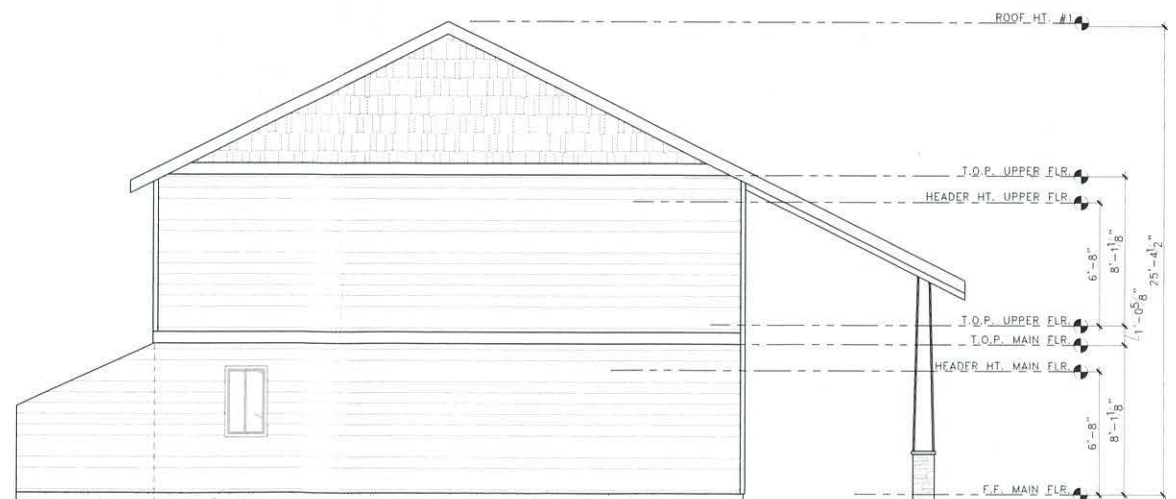

LEFT SIDE ELEVATION

1/4"=1'-0"

THE CONTRACTOR ASSUMES FULL RESPONSIBILITY FOR THE CORRECT INSTALLATION OF ALL EXTERIOR FINISHES AND WEATHERPROOFING.

INSTALLATION OF SIDING, HOUSE WRAP, AND WINDOWS TO BE PER CODE REQUIREMENTS AND MANUFACTURER'S INSTALLATION INSTRUCTIONS.

ELEVATIONS ARE ARTISTIC RENDERING'S ONLY.

NOTE:  
DESIGNER IS NOT AN ARCHITECT OR ENGINEER AND ASSUMES NO LIABILITY FOR THE PLANS IN PART OR WHOLE AND/OR THE CONSTRUCTION OF THE WORK CONTAINED HERE IN. A QUALIFIED PROFESSIONAL SHOULD REVIEW PLANS FOR ERRORS AND OMISSIONS. THESE PLANS SHOULD NOT BE UNDERTAKEN WITHOUT THE ASSISTANCE OF A QUALIFIED CONSTRUCTION PROFESSIONAL. THESE PLANS ARE INTENDED TO BE GUIDELINES FOR CONSTRUCTION. THE CONTRACTOR RESERVES THE RIGHT TO MAKE SUCH MINOR DEVIATIONS AS DEEMED NECESSARY AS LONG AS SUCH DEVIATIONS PROMOTE THE OVERALL EFFICACY AND AESTHETICS OF THE PLAN. CONTRACTOR SHALL VERIFY AND BE RESPONSIBLE FOR ALL DIMENSIONS AND CONDITIONS ON THE JOB. DESIGNER MUST BE NOTIFIED OF ANY DISCREPANCIES OR VARIATIONS OF AND FROM THESE DRAWINGS PRIOR TO WORK ON THE JOB

FOR CITY OFFICIAL USE

**TOPLINE**  
DRAFTING & DESIGN

THIS SET OF DRAWINGS IS THE PROPERTY OF TOPLINE DRAFTING & DESIGN. IT IS TO BE USED ONLY FOR THE PROJECT AND SITE SPECIFICALLY IDENTIFIED HEREON. IT IS NOT TO BE REPRODUCED, COPIED, REPRODUCED, OR TRANSMITTED IN ANY FORM OR BY ANY MEANS, ELECTRONIC OR MECHANICAL, INCLUDING PHOTOCOPYING, RECORDING, OR BY ANY INFORMATION STORAGE AND RETRIEVAL SYSTEM, WITHOUT THE WRITTEN PERMISSION OF TOPLINE DRAFTING & DESIGN. ANY UNAUTHORIZED USE OF THESE DRAWINGS IS STRICTLY PROHIBITED. TOPLINE DRAFTING & DESIGN, 1000 N. 10TH AVE., SUITE 100, PORTLAND, OR 97227. TEL: (503) 504-8318. FAX: (503) 504-8319. WWW.TOPLINE-DRAFTING.COM

Evgeni Shchegirev  
P.O.Box 156 Gervais, OR 97026  
evgeni@toplinednd.com  
Ph. (503)-504-8318

Mer edith Lodging  
48060 Breakers Bld.  
Neskowin, OR 97149

DATE: 12/7/2023  
SCALE: 1/4"=1'-0"  
DRAWN: ES  
JOB: 23-134  
SHEET:

3

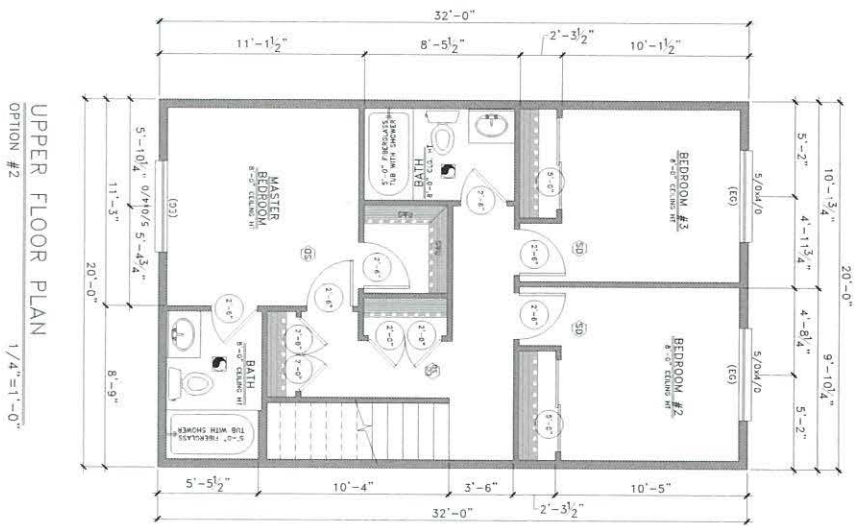
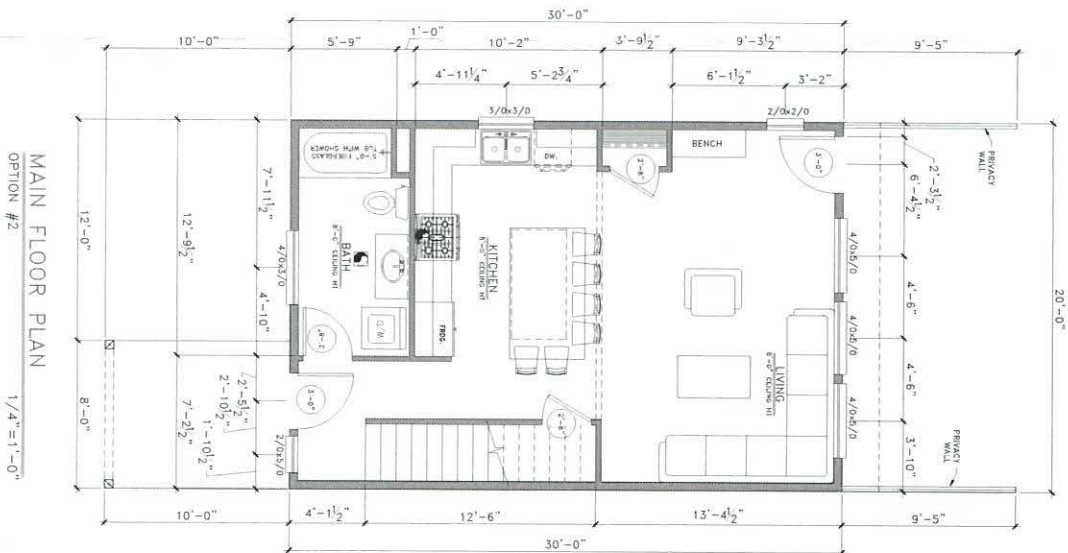
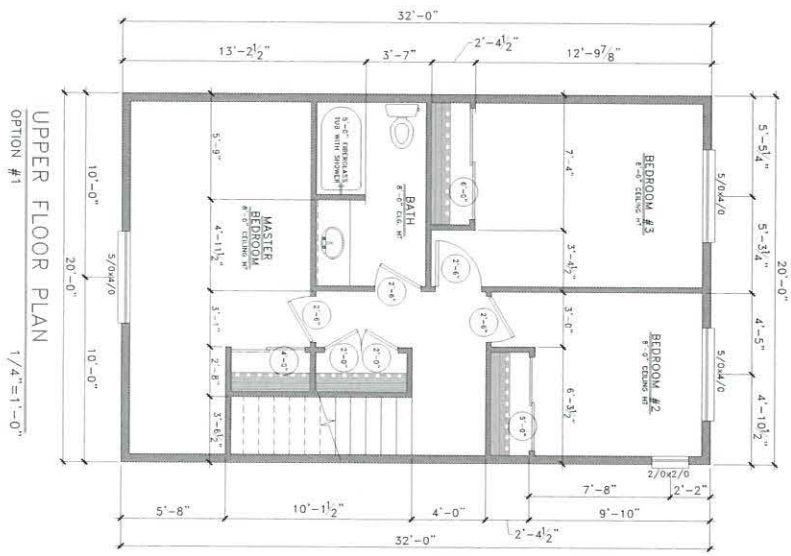
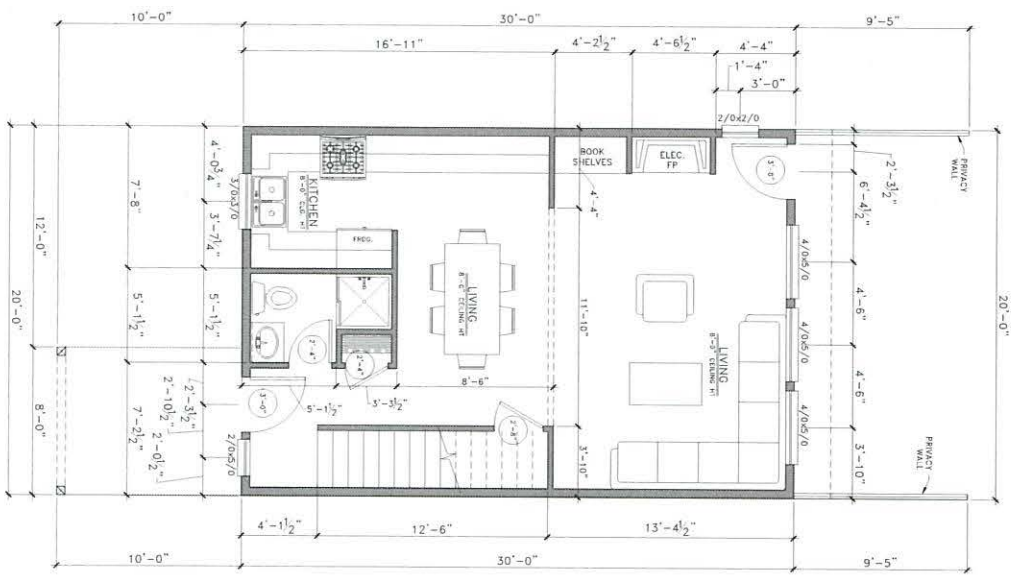

FOR CITY OFFICIAL USE

**NOTE:**  
THIS PLAN SET HAS BEEN PROVIDED TO THE CONTRACTOR FOR THE PURPOSE OF OBTAINING PERMITS AND SHALL BE THE CONTRACTOR'S RESPONSIBILITY TO VERIFY ALL DIMENSIONS AND CONDITIONS OF THE SITE AND TO MAKE ANY NECESSARY CHANGES TO THE PLAN SET. THE CONTRACTOR SHALL BE RESPONSIBLE FOR OBTAINING ALL NECESSARY PERMITS AND FOR VERIFYING THE ACCURACY OF ALL DIMENSIONS AND CONDITIONS OF THE SITE. THE CONTRACTOR SHALL BE RESPONSIBLE FOR OBTAINING ALL NECESSARY PERMITS AND FOR VERIFYING THE ACCURACY OF ALL DIMENSIONS AND CONDITIONS OF THE SITE. THE CONTRACTOR SHALL BE RESPONSIBLE FOR OBTAINING ALL NECESSARY PERMITS AND FOR VERIFYING THE ACCURACY OF ALL DIMENSIONS AND CONDITIONS OF THE SITE.



Evgeni Snegirev  
P.O.Box 156 Gervais, OR 97026  
evgeni@toplinednd.com  
Ph. (503-504-8318)

Meredith Lodging  
48060 Breakers Bld.  
Neskowin, OR 97149

DATE: 12/7/2023  
SCALE: 1/4"=1'-0"  
DRAWN: ES  
JOB: 23-134  
SHEET:



# H.G. Schlicker & Associates, Inc.

607 Main Street, Suite 200 · Oregon City, Oregon 97045  
(503) 655-8113 · FAX (503) 655-8173

Project #Y234676B

August 21, 2024

**To: Breakers Condominium  
Attn: Glenn Garrett, HOA President  
16476 NW Racely Court  
Portland, Oregon 97229**

**Subject: Addendum to  
Geotechnical Investigation (Phase 2) Report of April 23, 2024  
Regarding TCLUO Section 3.570(6)(a).  
Tax Lot 92411, Map 5S-11W-25CB Supp. Map No. 2  
Lot-Unit 11, 48060 Breakers Boulevard  
Neskowin, Tillamook County, Oregon**

**Dear Mr. Garrett:**

As requested, H.G. Schlicker and Associates, Inc. (HGSA) is providing this addendum letter to our May 23, 2023, Geologic Hazards Investigation and our April 23, 2024, Geotechnical Investigation report (HGSA #Y234676 and #Y234676B). The purpose of this addendum is to provide clarification to our engineering geologic recommendations with respect to the moveable structure design requirement set forth in section 3.570(6)(a) *Additional Development Limitations in Coastal Hazard Areas* of the Tillamook County Land Use Ordinance (TCLUO) Article 3.500.

Our report provides recommendations for the new house be placed on elevated beams supported on pile or columns with the lowest horizontal structural member no lower than 1 foot above the base flood elevation. We recommend that the foundation system consist of drilled and gravity grouted micropile. A *moveable structural design* is likely a structural engineering consideration related to the connection between the top of the pile and horizontal framing members.

Relocation of the structure, if threatened by coastal hazards within the footprint of the tax lot, may not be feasible due to its small size.

If moving the structure is necessary to a location off of the site, then the in-place constructed micropile would not be able to be moved or reused; however, the supported structure may be able to be disconnected and moved independently of the pile.



We can work with the structural engineer and architect during the design process to provide any engineering geologic feedback related to the pile system design to help achieve a building design that conforms with the intent of Section 3.570(6)(a) of TCLUO.

HGSA's review of final plans and specifications is necessary to determine whether the recommendations detailed in this report have been properly interpreted and incorporated into the design and construction documents. At the completion of our review, we will issue a letter of conformance to the client for the plans and specifications.

If you have any questions concerning this letter or the site, please contact us.

Respectfully submitted,

**H.G. SCHLICHER AND ASSOCIATES, INC.**



EXPIRES: 12/31/2024

Adam M. Large, MSc, RG, CEG  
President/Principal Engineering Geologist  
AML:mgb